

A
B
C
D
E
F
G
H
I
J
K
L
M
N



SHEET INDEX

SHEET	DESCRIPTION
FA-00.0	VESDA FIRE ALARM TITLE SHEET
FA-01.0	VESDA FIRE ALARM PLAN - 6TH FLOOR
FA-01.1	VESDA FIRE ALARM PLAN - 6TH FLOOR
FA-01.2	VESDA FIRE ALARM PLAN - 6TH FLOOR
FA-02.0	VESDA FIRE ALARM PLAN - STAGE
FA-02.1	VESDA FIRE ALARM PLAN - STAGE

APPLICABLE CODES

DESIGN AND CONSTRUCTION SHALL CONFORM TO ALL FEDERAL, STATE AND LOCAL BUILDING CODES AND ORDINANCES TO INCLUDE BUT NOT LIMITED TO THE MOST CURRENT VERSION OF THE FOLLOWING DOCUMENTS:

- 2019 CALIFORNIA BUILDING CODE PART 2 OF TITLE 24
- 2019 CALIFORNIA ELECTRIC CODE PART 3 OF TITLE 24
- 2019 CALIFORNIA MECHANICAL CODE PART 4 OF TITLE 24
- 2019 CALIFORNIA FIRE CODE PART 9 OF TITLE 24
- ACCESSIBILITY REGULATIONS AS PRESCRIBED BY THE 2018 CALIFORNIA BUILDING CODE, CHAPTER 11
- AMERICANS WITH DISABILITIES ACT GUIDELINES, AS AMENDED, 28 CFR PART 36 AND 36, CFR 1911.
- ALL CODES AND ORDINANCES ADOPTED BY THE CITY OF SAN DIEGO.
- UL288 6TH EDITION LIMIT
- 2016 NFPA 72
- 2016 NFPA 76

SCOPE OF WORK

NEW ASPIRATING SMOKE DETECTION IN EXISTING LOCATIONS.
NO NEW MECHANICAL DEVICES.

FIRE MARSHAL REQUIRED NOTES

1. THE INSTALLATION OF THE ASPIRATING FIRE ALARM SYSTEM SHALL COMPLY WITH THE CALIFORNIA CODE OF REGULATIONS, TITLE 24, 2019 EDITION (PARTS 2.3.4 AND 9); CALIFORNIA BUILDING CODE, 2019; CALIFORNIA ELECTRICAL CODE, 2019; CALIFORNIA MECHANICAL CODE, 2019; CALIFORNIA FIRE CODE, 2019; NFPA 72, 2019 EDITION AND NFPA 76, 2018 EDITION CITY OF SAN DIEGO TECHNICAL BULLETINS.
2. UPON COMPLETION OF THE INSTALLATION OF THE FIRE ALARM SYSTEM, A SATISFACTORY TEST OF THE ENTIRE SYSTEM SHALL BE PERFORMED IN THE PRESENCE OF THE CITY OF SAN DIEGO DEPUTY FIRE MARSHAL.
3. FIRE ALARM INSTALLER IN CHARGE OF THIS PROJECT MUST BE "STATE CERTIFIED" WITH THE DIVISION OF APPRENTICESHIP STANDARDS, AND SHALL FURNISH ID CARD UPON REQUEST OF THE SAN DIEGO DEPUTY FIRE MARSHAL.
4. DRAWING STORAGE WILL BE PROVIDED NEXT TO THE REQUIRED WORK TABLE.

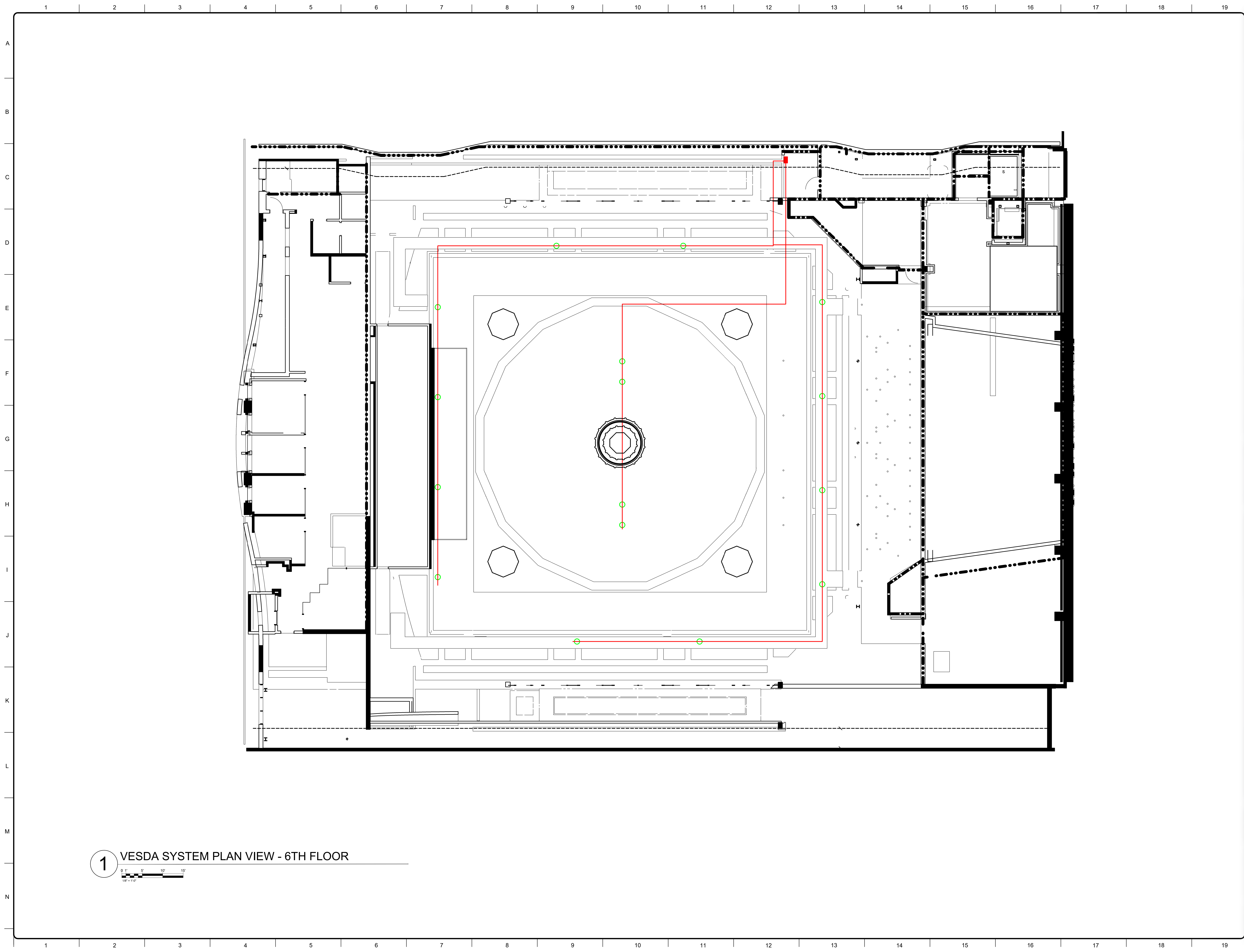

1 VESDA SYSTEM PLAN VIEW - 6TH FLOOR

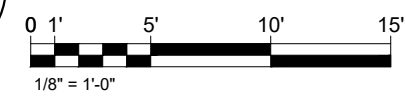

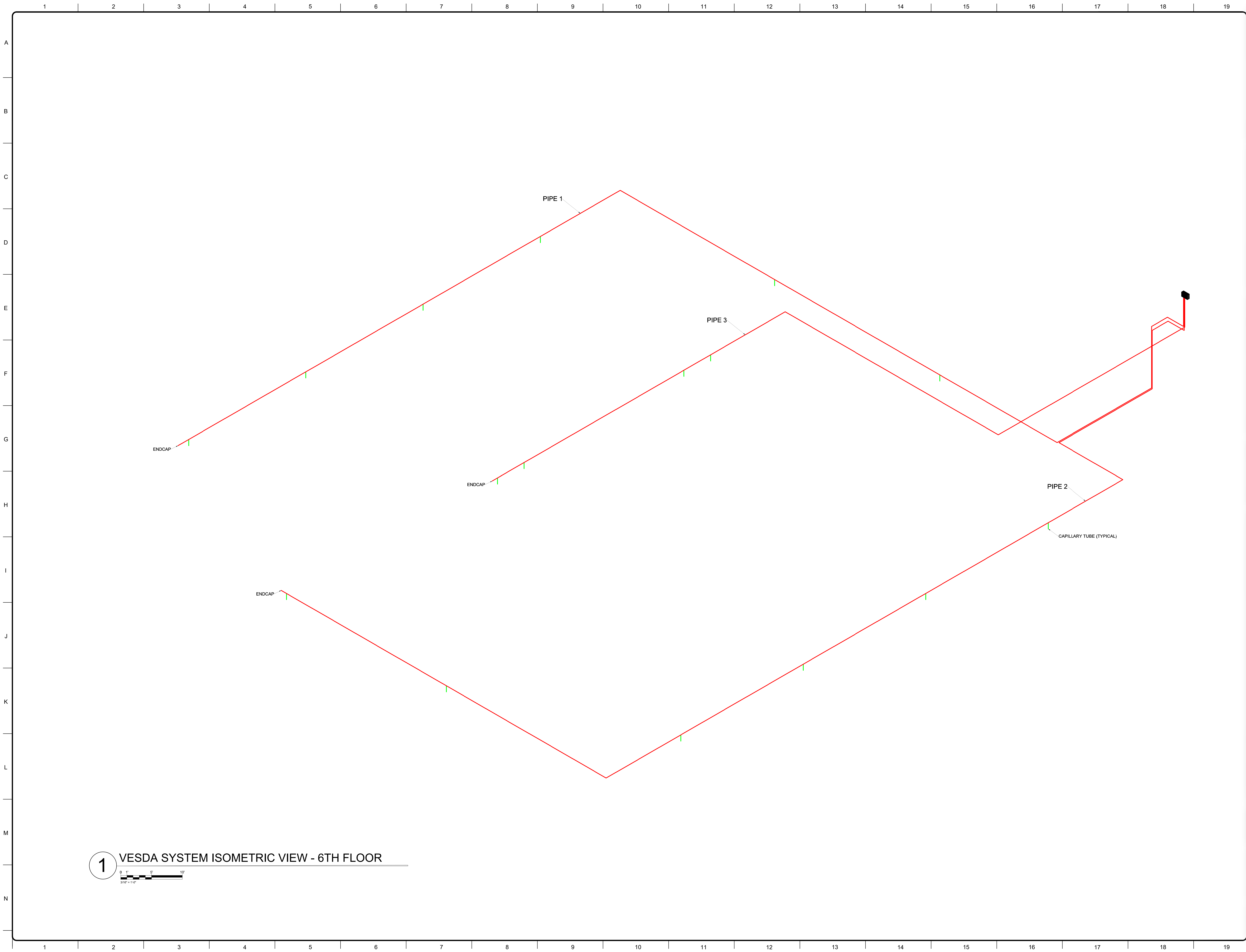

1 VESDA SYSTEM ISOMETRIC VIEW - 6TH FLOOR

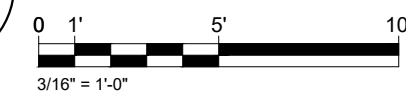

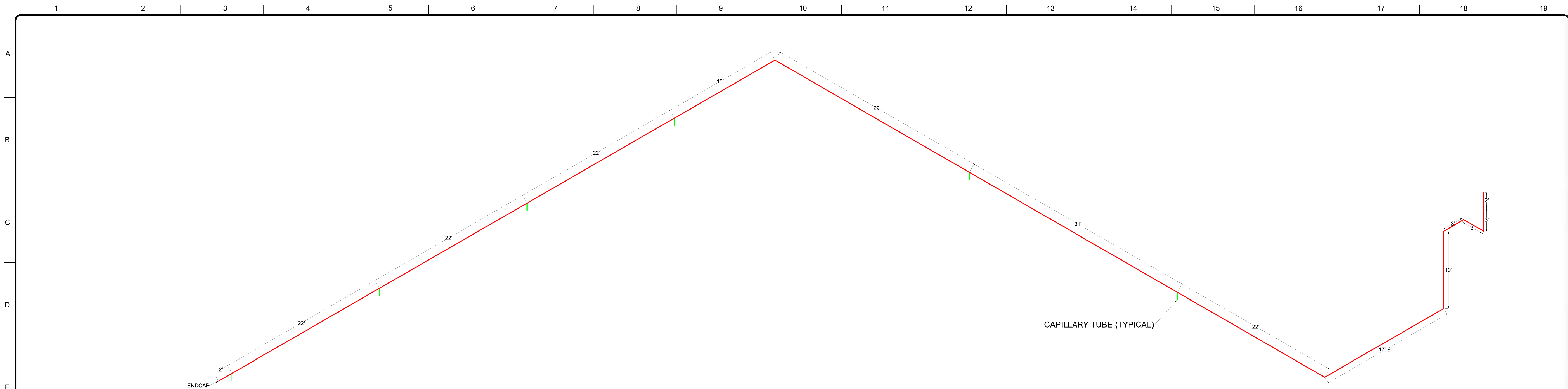

1 VESDA SYSTEM PIPE 1 MEASUREMENTS - 6TH FLOOR

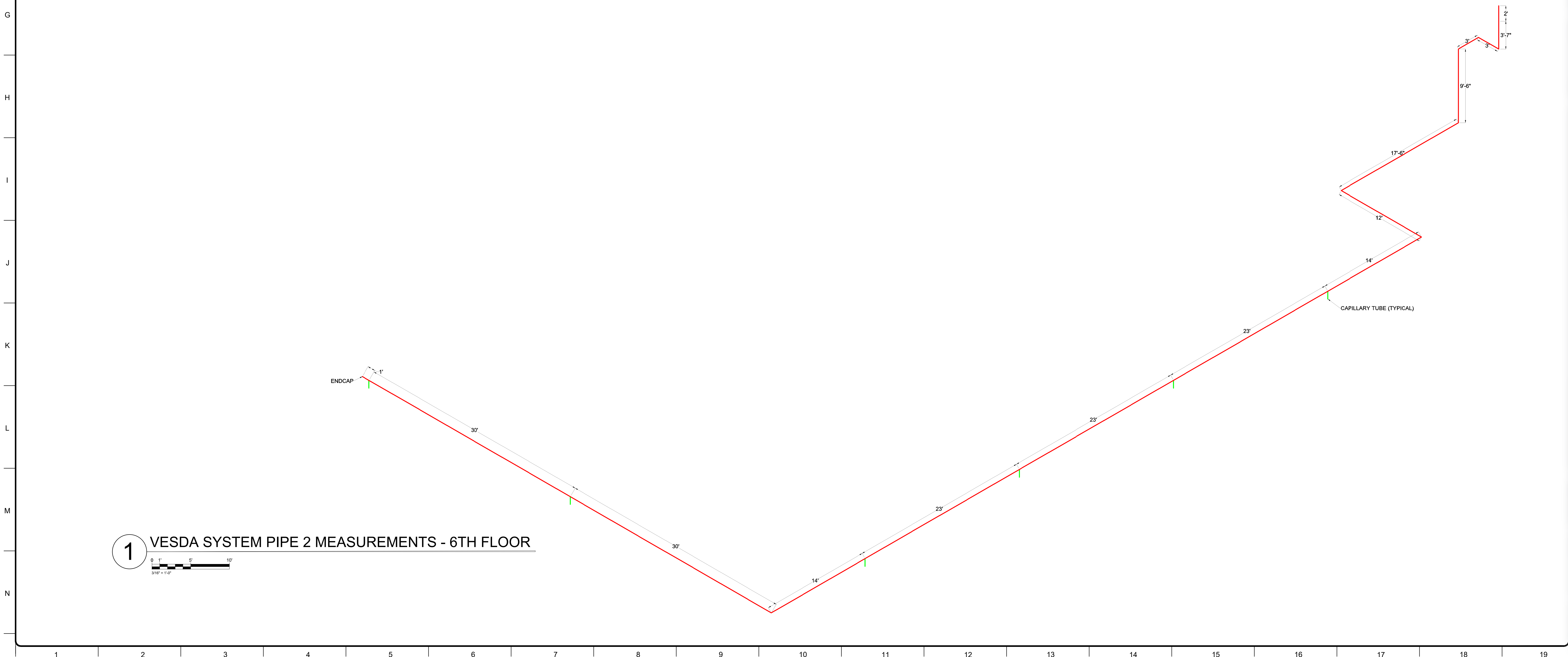

1 VESDA SYSTEM PIPE 2 MEASUREMENTS - 6TH FLOOR

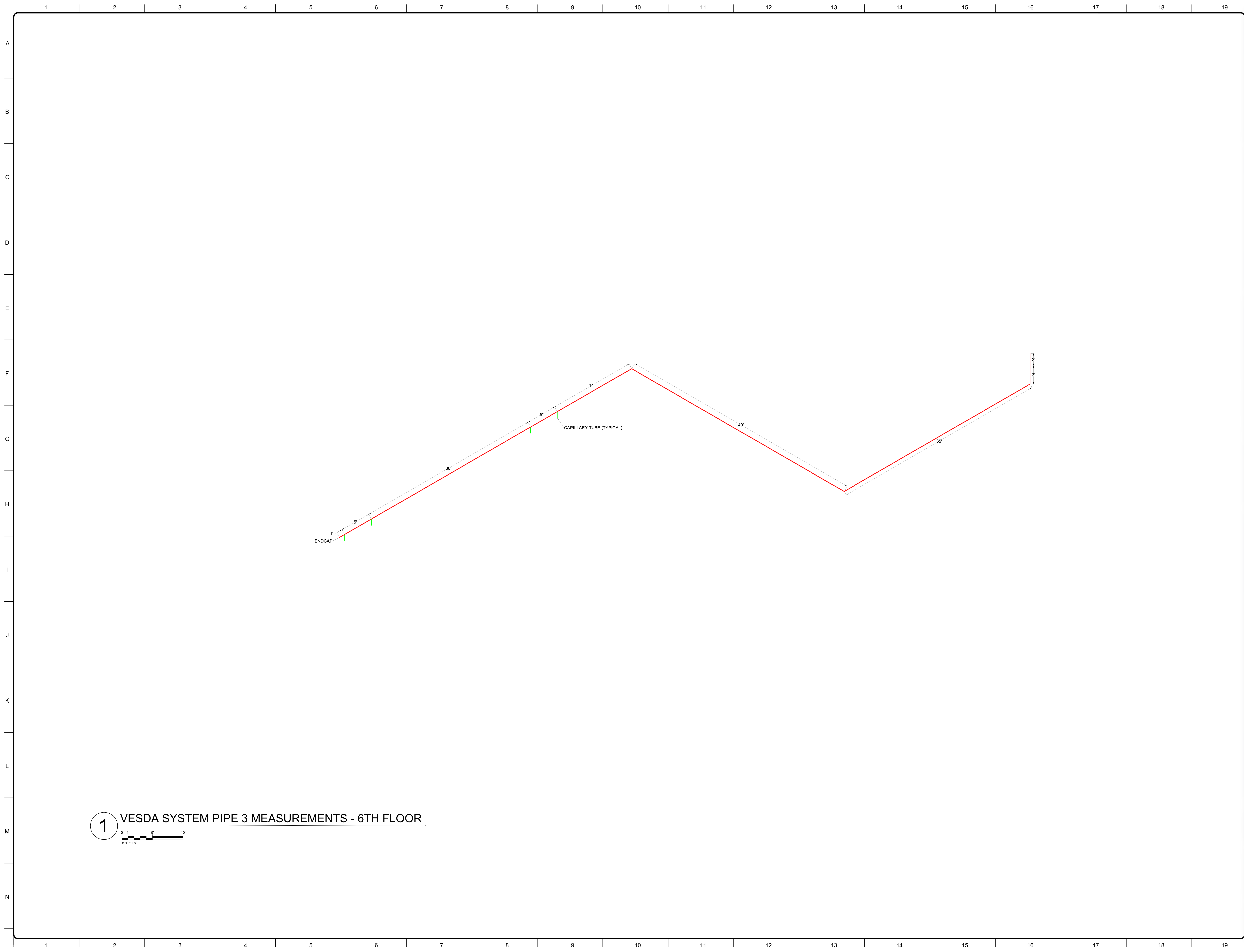

1 VESDA SYSTEM PIPE 3 MEASUREMENTS - 6TH FLOOR

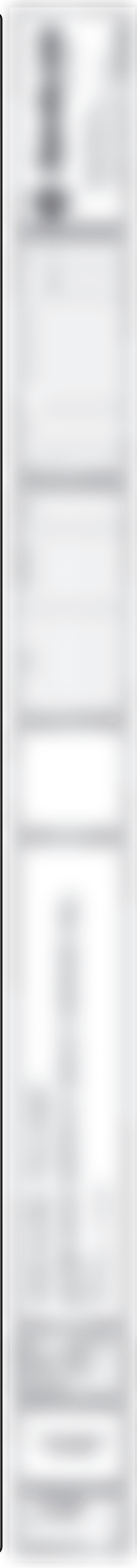
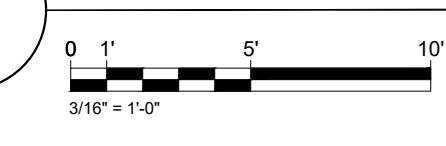

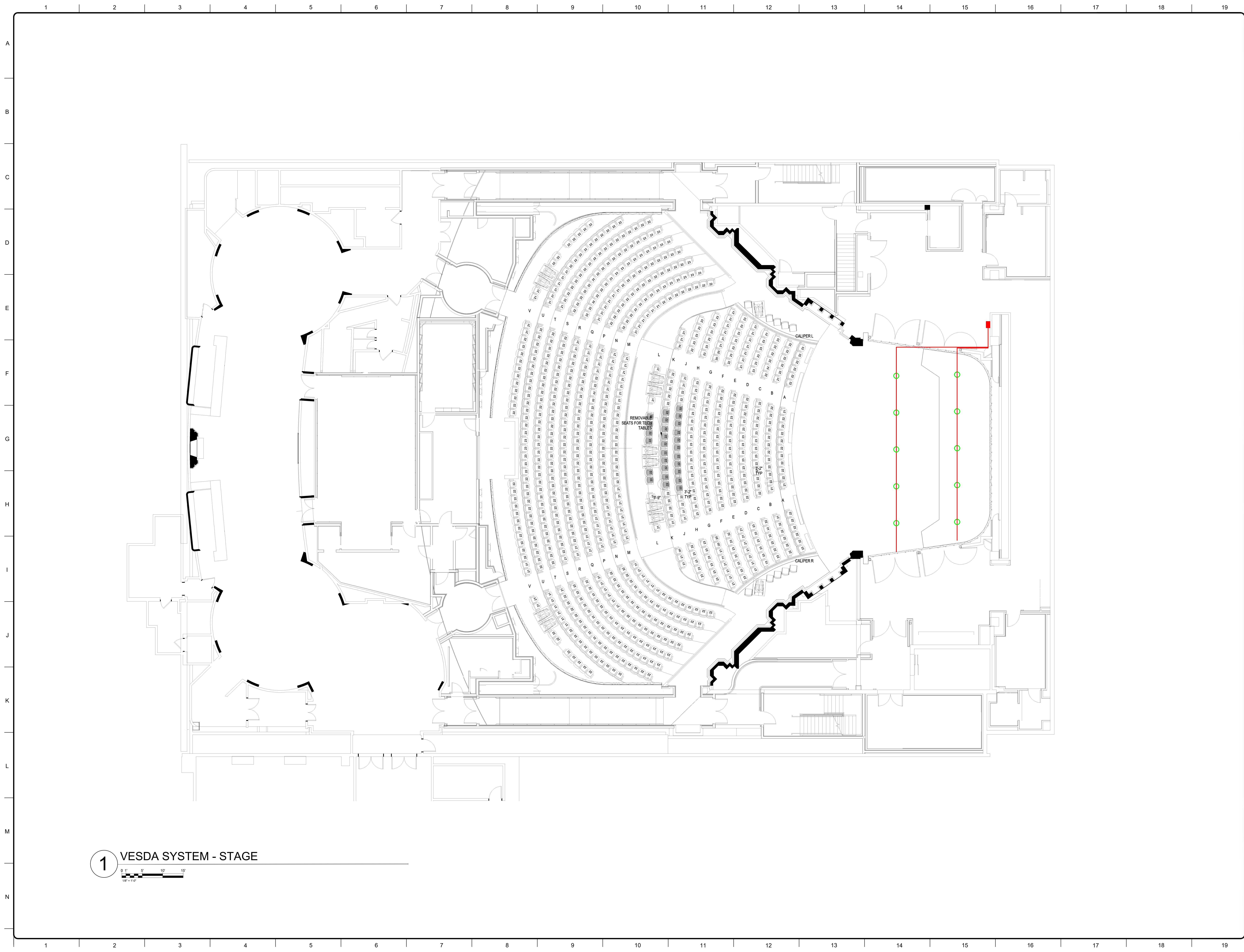

1 VESDA SYSTEM - STAGE

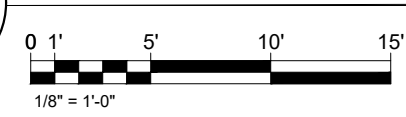

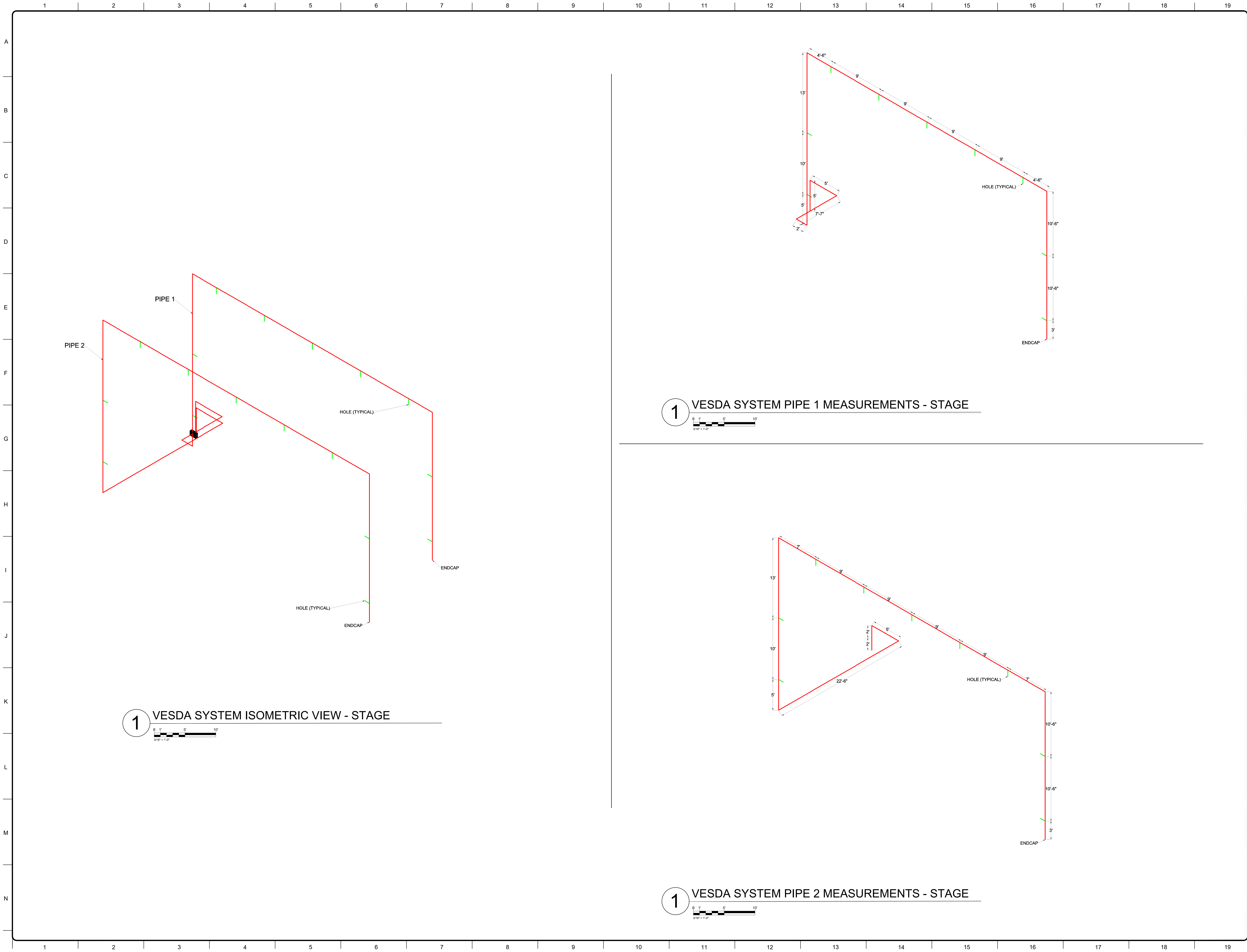

1
 2
 3
 4
 5
 6
 7
 8
 9
 10
 11
 12
 13
 14
 15
 16
 17
 18
 19
 A
 B
 C
 D
 E
 F
 G
 H
 I
 J
 K
 L
 M
 N



Installation Data Pack for

Pipe Type	America
Date	11/1/22
Units	US
Altitude	100'
Designed with Hole Sizes	5/64";1/8";9/64"

Detector : 6th fl Detector

Type	VEU
Sensitivity Objective	NFPA_SFD
NFPA-UL268 6th Edition Limit	SFD
Endcap Usage	Create a Balanced Design
Application Defaults	default
Aspirator Speed	5
Air Temperature	68.0°F
Absolute Pressure	1006hPa
System Flowrate	89.9l/min
Total Pipe Length	543' 4"
Number Of Sample Points	16
Maximum Transport Time	80sec
Maximum Allowed TT	120sec
Minimum Hole Flow Rate	2.0l/min
Exhaust Length	6'
Exhaust Diameter	0.874
Exhaust Pressure Drop	28Pa
Invert	Yes

Thresholds

Safety Factor (% reduction in alarm threshold) 10%

	Alert	Action	Fire 1	Fire 2
Recommended Thresholds (%/ft)	0.0405	0.0812	0.1623	0.3246
Smoke at least sensitive hole (%/ft)	0.7812	1.5625	3.1250	6.2500

Group Details

	Hole Sensitivity	Flow	Pressure	Transport Time	Hole Diameter	[Default Group]
Aggregate smoke from holes						0
Group Type						
Max Target Aggregate Sensitivity						
Min Target Aggregate Sensitivity						
Contribution ratio(%)						
Applied Max Aggregate Sensitivity						
Applied Min Aggregate Sensitivity						
Target Suction Pressure						25
Target Balance						70
Exclude from Autobalance						
1:Section0-1	2.4261	6.0	145	15	1/8"	✓
1:Section0-2	2.5499	5.7	131	21	1/8"	✓
1:Section0-3	2.7023	5.4	116	31	1/8"	✓
1:Section0-4	2.7555	5.3	112	38	1/8"	✓
1:Section0-5	2.7924	5.2	109	48	1/8"	✓
1:Section0-6	2.8113	5.2	108	69	1/8"	✓
2:Section0-1	2.4580	5.9	141	16	1/8"	✓
2:Section0-2	2.5537	5.7	130	20	1/8"	✓
2:Section0-3	2.6304	5.5	123	25	1/8"	✓
2:Section0-4	2.6833	5.4	118	32	1/8"	✓
2:Section0-5	2.7553	5.3	112	52	1/8"	✓
2:Section0-6	2.7806	5.2	110	80	1/8"	✓
3:Section0-1	2.4171	6.0	146	25	1/8"	✓
3:Section0-2	2.4274	6.0	144	26	1/8"	✓
3:Section0-3	2.4668	5.9	140	38	1/8"	✓
3:Section0-4	2.4702	5.9	139	44	1/8"	✓
Number of holes						16
Flow Share(%)						100
Aggregate Sensitivity						
Balance(%)						86
Suction pressure (least)						108

Pipe:Pipe 1

Total Pipe Length 201' 9"
Ambient Pressure 0Pa
Sector Pressure 241Pa
Number of Sample Points 6
Pipe Flowrate 32.8l/min

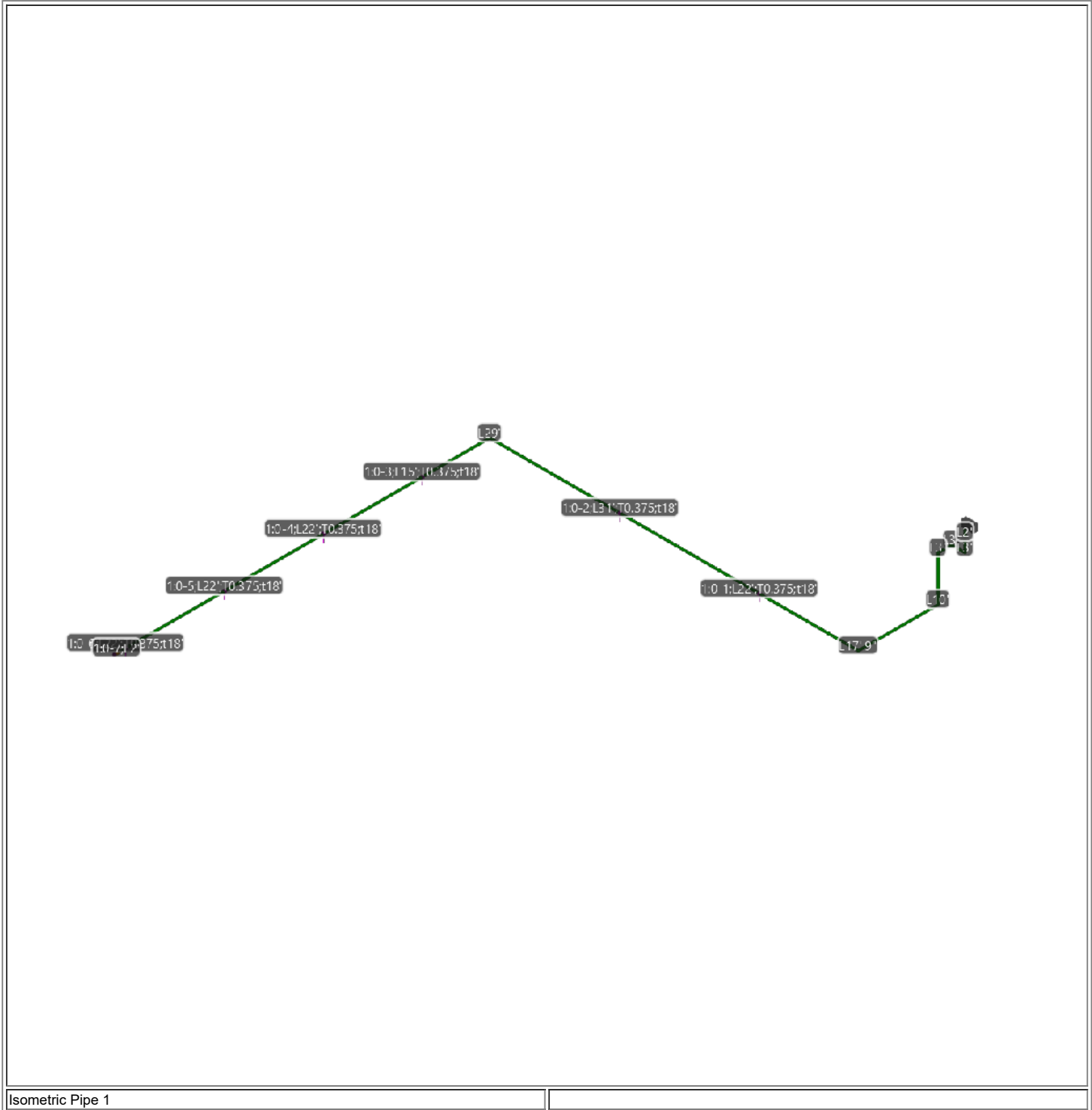

Section0

Pipe Diameter 0.874

#	Distance ft	Relative ft	Direction	Hole Diameter in	Capillary Length ft	Transport Time sec	Pressure Pa	Flow l/min	Flow %	Hole Sensitivity %/ft	Pipe Diameter in	Capillary Diameter in	Intersection Pressure Pa
---	----------------	----------------	-----------	------------------------	---------------------------	--------------------------	----------------	---------------	-----------	-----------------------------	------------------------	-----------------------------	--------------------------------

-	Socket Union	2'	2'									0.874		
-	Bend 90	5'	3'	L										
-	Bend 90	8'	3'	B										
-	Bend 90	11'	3'	D										
-	Bend 90	21'	10'	B										
-	Bend 90	38' 9"	17' 9"	L										
1:Section0-1	Capillary	60' 9"	22'		1/8"	18'	15	145	6.0	6.7	2.4261	0.874	0.375	194
1:Section0-2	Capillary	91' 9"	31'		1/8"	18'	21	131	5.7	6.4	2.5499	0.874	0.375	177
-	Bend 90	120' 9"	29'	B										
1:Section0-3	Capillary	135' 9"	15'		1/8"	18'	31	116	5.4	6.0	2.7023	0.874	0.375	161
1:Section0-4	Capillary	157' 9"	22'		1/8"	18'	38	112	5.3	5.9	2.7555	0.874	0.375	155
1:Section0-5	Capillary	179' 9"	22'		1/8"	18'	48	109	5.2	5.8	2.7924	0.874	0.375	152
1:Section0-6	Capillary	201' 9"	22'		1/8"	18'	69	108	5.2	5.8	2.8113	0.874	0.375	150
1:Section0-7	Test Point	203' 9"	2'		1/8"		52	123	5.6	0.0		0.874		
<p>A Test Point is not a Sample hole, and does not form part of the detection system. Test Points are used only during commissioning to measure transport time and then only one at a time. The Test Point must be blocked during normal operation.</p>														

Pipe:Pipe 2

Total Pipe Length 207' 7"
Ambient Pressure 0Pa
Sector Pressure 241Pa
Number of Sample Points 6
Pipe Flowrate 33.2l/min

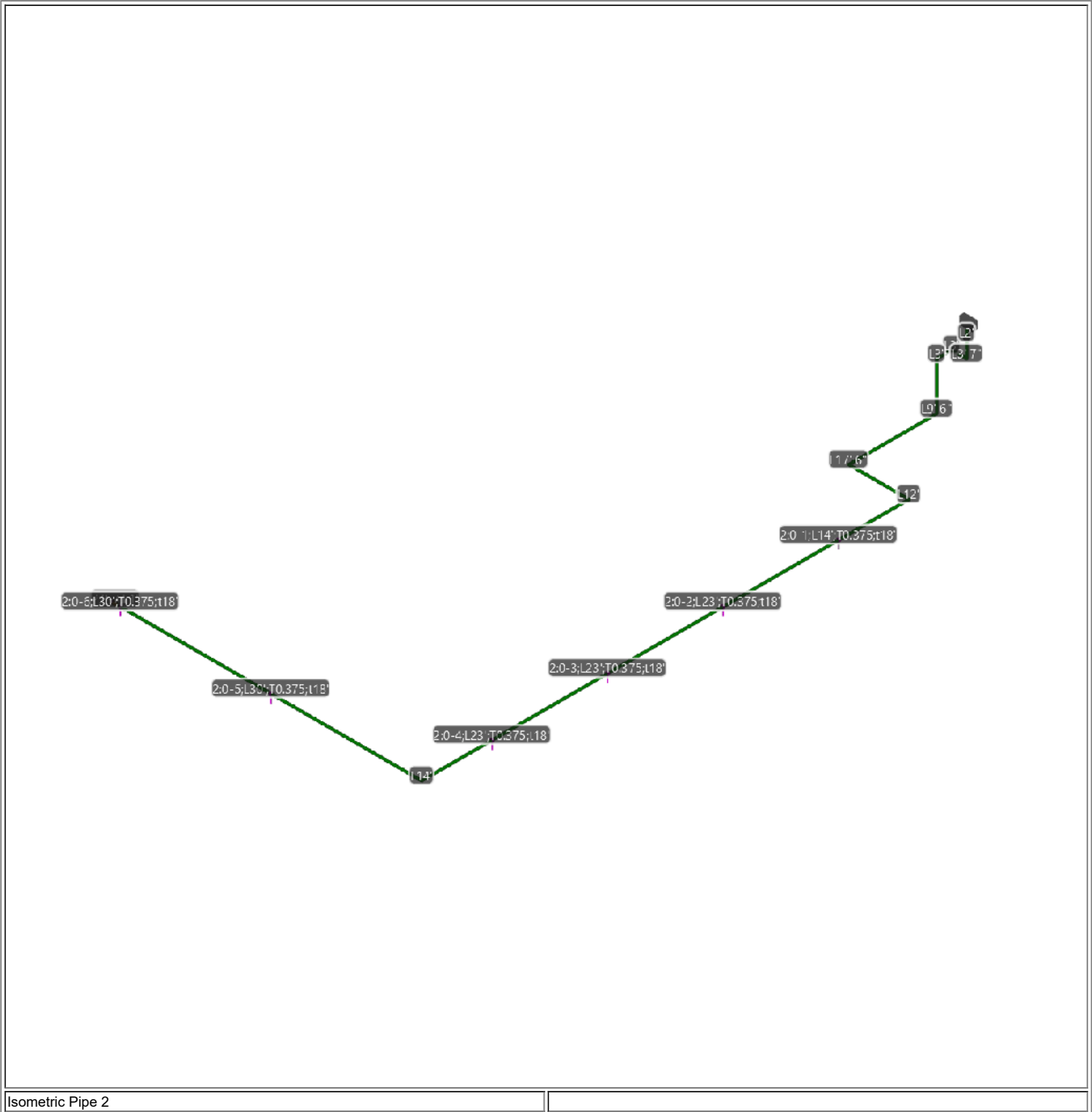

Isometric Pipe 2

Section0

Pipe Diameter 0.874

#	Distance ft	Relative ft	Direction	Hole Diameter in	Capillary Length ft	Transport Time sec	Pressure Pa	Flow l/min	Flow %	Hole Sensitivity %/ft	Pipe Diameter in	Capillary Diameter in	Intersection Pressure Pa
---	----------------	----------------	-----------	------------------------	---------------------------	--------------------------	----------------	---------------	-----------	-----------------------------	------------------------	-----------------------------	--------------------------------

-	Socket Union	2'	2'									0.874		
-	Bend 90	5' 7"	3' 7"	L										
-	Bend 90	8' 7"	3'	B										
-	Bend 90	11' 7"	3'	D										
-	Bend 90	21' 1"	9' 6"	B										
-	Bend 90	38' 7"	17' 6"	R										
-	Bend 90	50' 7"	12'	B										
2:Section0-1	Capillary	64' 7"	14'		1/8"	18'	16	141	5.9	6.6	2.4580	0.874	0.375	189
2:Section0-2	Capillary	87' 7"	23'		1/8"	18'	20	130	5.7	6.4	2.5537	0.874	0.375	177
2:Section0-3	Capillary	110' 7"	23'		1/8"	18'	25	123	5.5	6.2	2.6304	0.874	0.375	168
2:Section0-4	Capillary	133' 7"	23'		1/8"	18'	32	118	5.4	6.0	2.6833	0.874	0.375	162
-	Bend 90	147' 7"	14'	L										
2:Section0-5	Capillary	177' 7"	30'		1/8"	18'	52	112	5.3	5.9	2.7553	0.874	0.375	155
2:Section0-6	Capillary	207' 7"	30'		1/8"	18'	80	110	5.2	5.8	2.7806	0.874	0.375	153
2:Section0-7	Test Point	208' 7"	1'		1/8"		57	125	5.6	0.0		0.874		
<p>A Test Point is not a Sample hole, and does not form part of the detection system. Test Points are used only during commissioning to measure transport time and then only one at a time. The Test Point must be blocked during normal operation.</p>														

Pipe:Pipe 3

Total Pipe Length 134'
 Ambient Pressure 0Pa
 Sector Pressure 244Pa
 Number of Sample Points 4
 Pipe Flowrate 23.9l/min

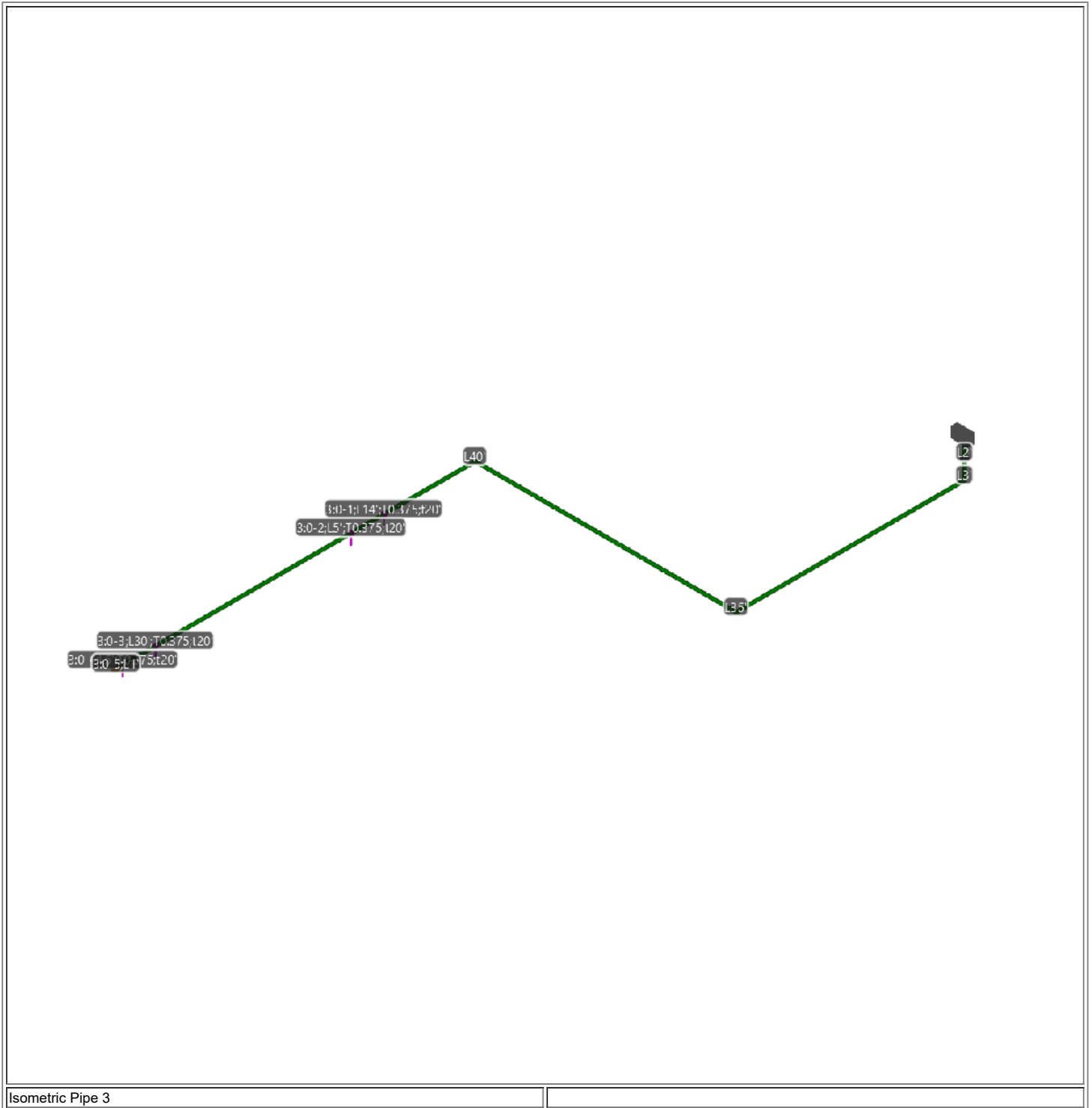

Section0

Pipe Diameter 0.874

#	Distance ft	Relative ft	Direction	Hole Diameter in	Capillary Length ft	Transport Time sec	Pressure Pa	Flow l/min	Flow %	Hole Sensitivity %/ft	Pipe Diameter in	Capillary Diameter in	Intersection Pressure Pa
---	----------------	----------------	-----------	------------------------	---------------------------	--------------------------	----------------	---------------	-----------	-----------------------------	------------------------	-----------------------------	--------------------------------

-	Socket Union	2'	2'									0.874		
-	Bend 90	5'	3'	B										
-	Bend 90	40'	35'	L										
-	Bend 90	80'	40'	B										
3:Section0-1	Capillary	94'	14'		1/8"	20'	25	146	6.0	6.7	2.4171	0.874	0.375	200
3:Section0-2	Capillary	99'	5'		1/8"	20'	26	144	6.0	6.7	2.4274	0.874	0.375	199
3:Section0-3	Capillary	129'	30'		1/8"	20'	38	140	5.9	6.6	2.4668	0.874	0.375	193
3:Section0-4	Capillary	134'	5'		1/8"	20'	44	139	5.9	6.6	2.4702	0.874	0.375	193
3:Section0-5	Endcap	135'	1'		0"							0.874		





Bill Of Materials

Name

Site Address

Calculated By

Installer

Date 11/1/22

Detector : 6th fl Detector

	Part Id	Description	Quantity	Packages
1	E700-CAP-KIT	Plastic Capillary Tube Sampling Connectors	16	16
2	E700-SP-DCL-PNT	Sampling Point Label	16	1
3	E700-TUBE	Capillary tube 3/8" internal diameter	296'	6
4	VEU	VEU	1	1
5	VP-CLIP	Pipe Clip single point fix	111*	3
6	VP-COUP	Coupling	19	2
7	VP-EC	Endcap	1	1
8	VP-ELB-90	90 degrees Elbow	16	1
9	VP-P-210	VESDA pipe: 15 lengths of PVC Pipe with 0.874 ID / 1.05 OD	37	3
10	VP-TEE-FPT	Trunk Adaptor for capillary tubes	16	2
11	VP-UNION	Socket Union	3	1
12	VSP-877	Flush Mount sampling point	16	16
13	VSP-878	Push-in Connect Adaptor Kit for 1/2" Capillary Tubing	16	16
14	VSP-TP-KIT-US	Test Point	2	2

Notes

*Based on clip spacing of 5'





Installation Data Pack for

Site Address
Pipe Type America
Date 11/1/22
Units US
Altitude 100'
Designed with Hole Sizes 5/64";1/8"

Detector : Stage Detector - 1st FI Lobby

Type	VEU
Sensitivity Objective	NFPA_VEWFD
NFPA-UL268 6th Edition Limit	VEWFD
Endcap Usage	Create a Balanced Design
Application Defaults	default
Aspirator Speed	5
Air Temperature	68.0°F
Absolute Pressure	1006hPa
System Flowrate	97.2l/min
Total Pipe Length	245' 7"
Number Of Sample Points	18
Maximum Transport Time	43sec
Maximum Allowed TT	60sec
Minimum Hole Flow Rate	2.0l/min
Exhaust Length	0'
Exhaust Diameter	0.874
Exhaust Pressure Drop	0Pa
Invert	No

Thresholds

Safety Factor (% reduction in alarm threshold) 10%

	Alert	Action	Fire 1	Fire 2
Recommended Thresholds (%/ft)	0.0093	0.0187	0.0467	0.0934
Smoke at least sensitive hole (%/ft)	0.2000	0.4000	1.0000	2.0000

Group Details

	Hole Sensitivity	Flow	Pressure	Transport Time	Hole Diameter	[Default Group]
Aggregate smoke from holes						0
Group Type						
Max Target Aggregate Sensitivity						
Min Target Aggregate Sensitivity						
Contribution ratio(%)						
Applied Max Aggregate Sensitivity						
Applied Min Aggregate Sensitivity						
Target Suction Pressure						25
Target Balance						70
Exclude from Autobalance						
1:Section0-1	0.7525	6.0	196	7	1/8"	✓
1:Section0-2	0.7765	5.8	185	9	1/8"	✓
1:Section0-3	0.8142	5.6	168	12	1/8"	✓
1:Section0-4	0.8289	5.5	162	13	1/8"	✓
1:Section0-5	0.8409	5.4	157	15	1/8"	✓
1:Section0-6	0.8501	5.3	154	17	1/8"	✓
1:Section0-7	0.8562	5.3	152	20	1/8"	✓
1:Section0-8	0.8635	5.3	149	28	1/8"	✓
1:Section0-9	0.8659	5.2	148	38	1/8"	✓
2:Section0-1	0.7756	5.9	185	9	1/8"	✓
2:Section0-2	0.7998	5.7	174	11	1/8"	✓
2:Section0-3	0.8435	5.4	156	14	1/8"	✓
2:Section0-4	0.8590	5.3	151	15	1/8"	✓
2:Section0-5	0.8718	5.2	146	17	1/8"	✓
2:Section0-6	0.8815	5.1	143	20	1/8"	✓
2:Section0-7	0.8880	5.1	141	23	1/8"	✓
2:Section0-8	0.8971	5.1	138	32	1/8"	✓
2:Section0-9	0.8997	5.0	137	43	1/8"	✓
Number of holes						18
Flow Share(%)						100
Aggregate Sensitivity						
Balance(%)						84
Suction pressure (least)						137

		ft	ft		in	sec	Pa	l/min		%/ft	in		
-	Socket Union	2'	2'								0.874		
-	Bend 90	5'	3'	L									
-	Bend 90	10'	5'	F									
-	Bend 90	17' 7"	7' 7"	L									
-	Bend 90	19' 7"	2'	U									
1:Section0-1	Hole	24' 7"	5'		1/8"	7	196	6.0	6.2	0.7525	0.874		
1:Section0-2	Hole	34' 7"	10'		1/8"	9	185	5.8	6.0	0.7765	0.874		
-	Bend 90	47' 7"	13'	L									
1:Section0-3	Hole	52' 1"	4' 6"		1/8"	12	168	5.6	5.7	0.8142	0.874		
1:Section0-4	Hole	61' 1"	9'		1/8"	13	162	5.5	5.6	0.8289	0.874		
1:Section0-5	Hole	70' 1"	9'		1/8"	15	157	5.4	5.6	0.8409	0.874		
1:Section0-6	Hole	79' 1"	9'		1/8"	17	154	5.3	5.5	0.8501	0.874		
1:Section0-7	Hole	88' 1"	9'		1/8"	20	152	5.3	5.5	0.8562	0.874		
-	Bend 90	92' 7"	4' 6"	D									
1:Section0-8	Hole	103' 1"	10' 6"		1/8"	28	149	5.3	5.4	0.8635	0.874		
1:Section0-9	Hole	113' 7"	10' 6"		1/8"	38	148	5.2	5.4	0.8659	0.874		
1:Section0-10	Endcap	116' 7"	3'		0"						0.874		

Pipe:Pipe 2

Total Pipe Length 132'
 Ambient Pressure 0Pa
 Sector Pressure 248Pa
 Number of Sample Points 9
 Pipe Flowrate 47.8l/min

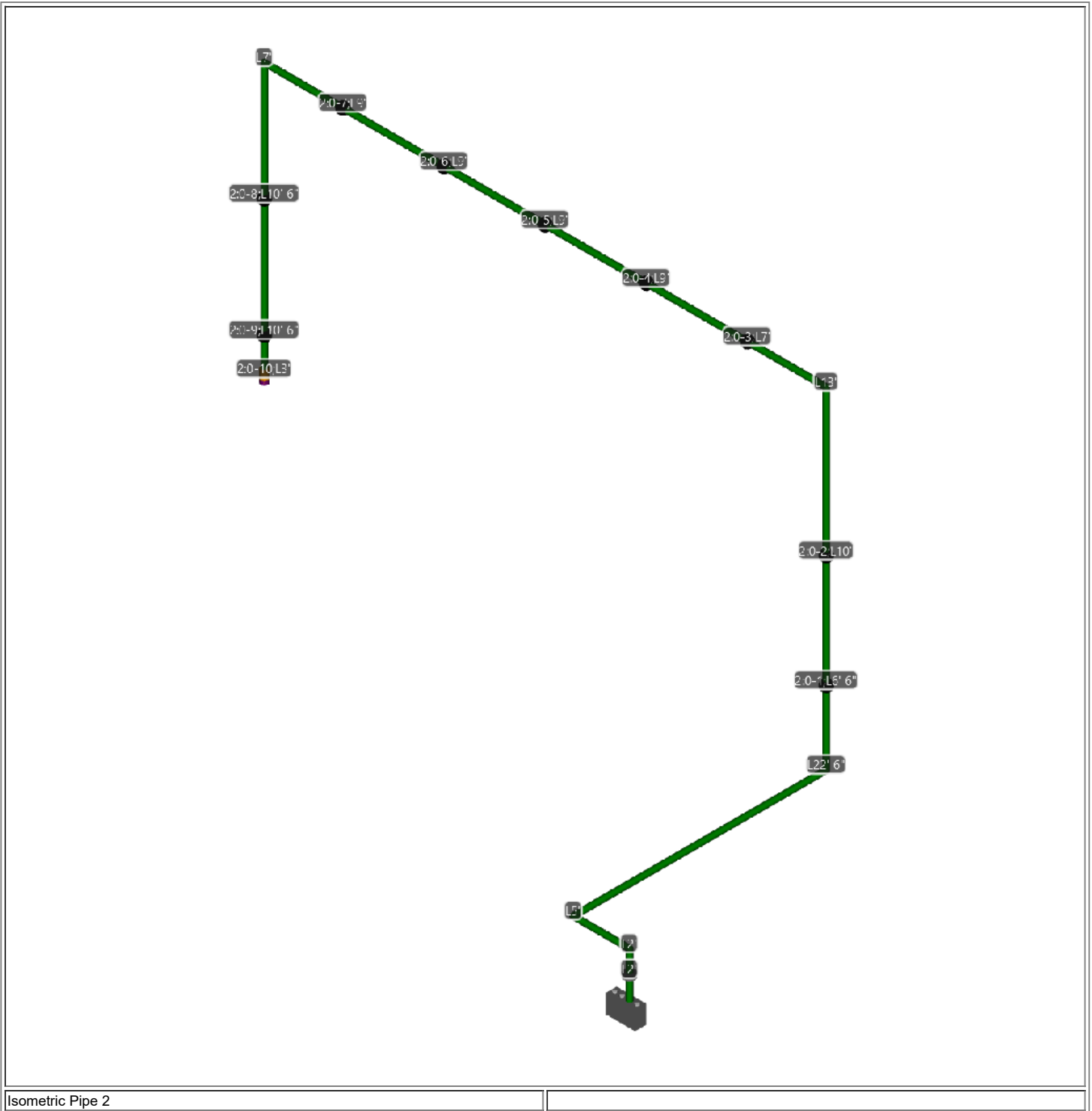

Section0

Pipe Diameter 0.874

#	Distance	Relative	Direction	Hole Diameter	Capillary Length	Transport Time	Pressure	Flow	Flow %	Hole Sensitivity	Pipe Diameter	Capillary Diameter	Intersection Pressure
---	----------	----------	-----------	---------------	------------------	----------------	----------	------	--------	------------------	---------------	--------------------	-----------------------

		ft	ft		in		sec	Pa	l/min		%/ft	in		
-	Socket Union	2'	2'									0.874		
-	Bend 90	4'	2'	L										
-	Bend 90	9'	5'	F										
-	Bend 90	31' 6"	22' 6"	U										
2:Section0-1	Hole	38'	6' 6"		1/8"		9	185	5.9	6.0	0.7756	0.874		
2:Section0-2	Hole	48'	10'		1/8"		11	174	5.7	5.8	0.7998	0.874		
-	Bend 90	61'	13'	L										
2:Section0-3	Hole	68'	7'		1/8"		14	156	5.4	5.5	0.8435	0.874		
2:Section0-4	Hole	77'	9'		1/8"		15	151	5.3	5.4	0.8590	0.874		
2:Section0-5	Hole	86'	9'		1/8"		17	146	5.2	5.4	0.8718	0.874		
2:Section0-6	Hole	95'	9'		1/8"		20	143	5.1	5.3	0.8815	0.874		
2:Section0-7	Hole	104'	9'		1/8"		23	141	5.1	5.3	0.8880	0.874		
-	Bend 90	111'	7'	D										
2:Section0-8	Hole	121' 6"	10' 6"		1/8"		32	138	5.1	5.2	0.8971	0.874		
2:Section0-9	Hole	132'	10' 6"		1/8"		43	137	5.0	5.2	0.8997	0.874		
2:Section0-10	Test Point	135'	3'		1/8"		37	115	5.4	0.0		0.874		
<p>A Test Point is not a Sample hole, and does not form part of the detection system. Test Points are used only during commissioning to measure transport time and then only one at a time. The Test Point must be blocked during normal operation.</p>														





Bill Of Materials

Name

Site Address

Calculated By

Installer

Date 11/1/22

Detector : Stage Detector - 1st FI Lobby

	Part Id	Description	Quantity	Packages
1	E700-SP-DCL-PNT	Sampling Point Label	18	1
2	VEU	VEU	1	1
3	VP-CLIP	Pipe Clip single point fix	51*	2
4	VP-COUP	Coupling	10	1
5	VP-EC	Endcap	1	1
6	VP-ELB-90	90 degrees Elbow	11	1
7	VP-P-210	VESDA pipe: 15 lengths of PVC Pipe with 0.874 ID / 1.05 OD	17	2
8	VP-UNION	Socket Union	2	1
9	VSP-TP-KIT-US	Test Point	1	1

Notes

*Based on clip spacing of 5'



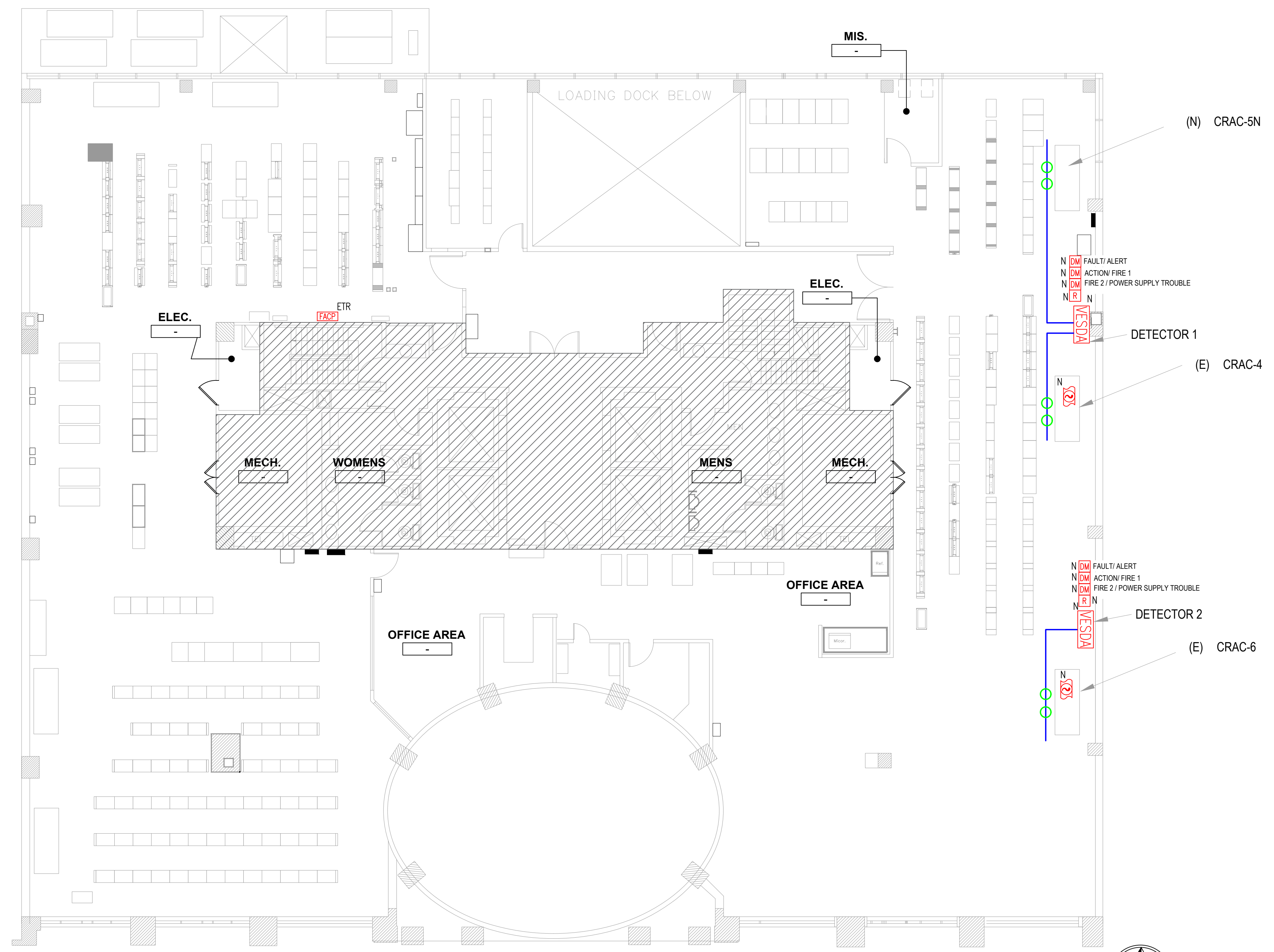

FIRE ALARM PLAN - 2nd FLOOR
 SCALE: 1/8"=1'-0"

FIRE ALARM SYMBOLS	
SYMBOL	DESCRIPTION
	VESDA ASPIRATING SMOKE DETECTION SYSTEM
	FIRE ALARM CONTROL PANEL
	STROBE - CEILING MOUNT
	HORN/STROBE - CEILING MOUNT
	STROBE - WALL MOUNT
	HORN/STROBE - WALL MOUNT
	DUAL MONITOR MODULE
	SHUTDOWN RELAY MODULE
	SMOKE DETECTOR
	DUCT SMOKE DETECTOR
N	DENOTES DEVICE IS NEW
ETR	DENOTES DEVICE IS EXISTING TO REMAIN
ENL	DENOTES DEVICE IS EXISTING BUT IN NEW LOCATION
#cd	DENOTES STROBE CANDELA RATING
N#C#	DENOTES NACP# AND CIRCUIT#
	DENOTES LOCATION OF END OF LINE RESISTOR
	VESDA ASPIRATING PIPE
	PIPE HOLE (VESDA SYSTEM)
	DENOTES AREA NOT IN CONTRACT

FIRE ALARM NOTE:
 THE FLOOR PLAN SHOWN IS BASED UPON CONTRACT DRAWINGS DESIGNED BY OTHERS. THEREFORE, MONA ELECTRIC IS NOT RESPONSIBLE FOR ANY DESIGN DEFICIENCIES.

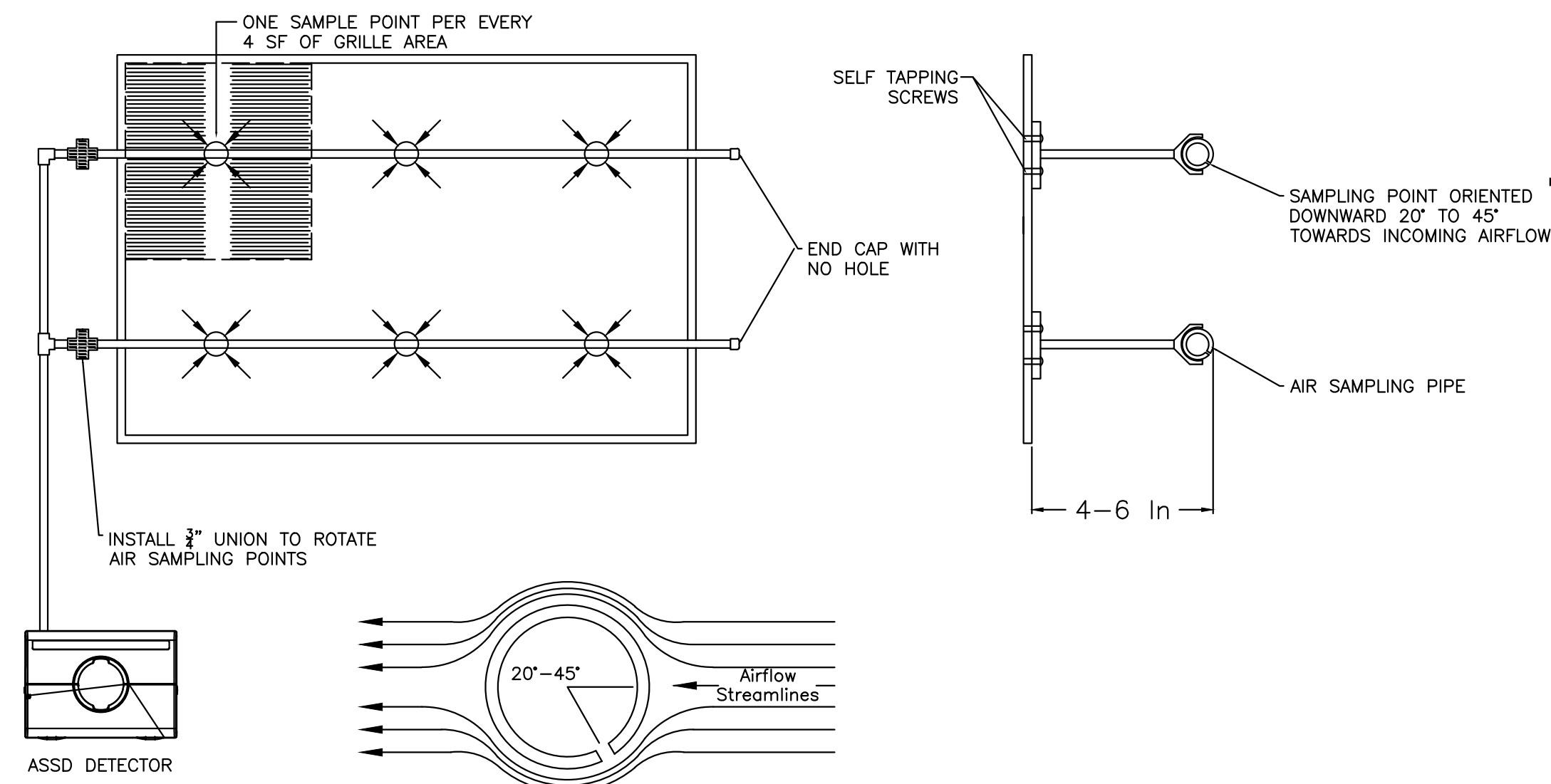

- NOTES:**
1. AIR SAMPLING PIPE DISTRIBUTION NETWORKS SHALL BE CONSTRUCTED USING RIGID PIPE MOUNTED TO FACE OF RETURN AIR GRILLES PRIOR TO FILTRATION.
 2. SAMPLING POINTS COVERING RETURN AIR GRILLES SHALL STANDOFF 4 TO 6 INCHES FROM THE GRILLE IN ORDER TO AVOID THE LOW OR NEGATIVE PRESSURE POINT DIRECTLY AT THE GRILLE SURFACE.
 3. MECHANICAL PIPE FASTENERS AND HANGARS SHALL BE APPROVED FOR USE WITH THE PIPE MATERIAL IN WHICH IT IS SUPPORTING.
 4. SAMPLING POINTS SHALL BE DRILLED DIRECTLY INTO THE AIR SAMPLING PIPE DISTRIBUTION NETWORK AND BE ORIENTED 20-45° TOWARDS THE INCOMING AIRFLOW.
 5. ALL SAMPLING POINTS SHALL BE IDENTIFIABLE USING MANUFACTURER PROVIDED WRAP AROUND TYPE LABELING.
 6. SAMPLING POINT SPACING SHALL BE BASED UPON SAMPLING POINT DISTRIBUTION OF MINIMUM ONE (1) SAMPLING POINT PER 4 SQ. FT. OF GRILLE AREA.
 7. SAMPLING POINTS SHALL NOT BE PLACED OUTSIDE OF GRILLE AREA.
 8. A MEANS TO DISCONNECT THE SAMPLING PIPE FROM RETURN AIR GRILLES SHALL BE PROVIDED AND BASED ON MANUFACTURER'S GUIDELINES.
 9. SAMPLING POINTS SIZED IN ACCORDANCE WITH ASPIRE CALCULATIONS.
 10. MAXIMUM TRANSPORT TIME FROM THE LAST SAMPLE POINT ON EACH PIPE RUN SHALL NOT EXCEED 60 SECONDS.

1 TYPICAL RETURN AIR MONITORING SAMPLING DETAIL

SCALE: NONE

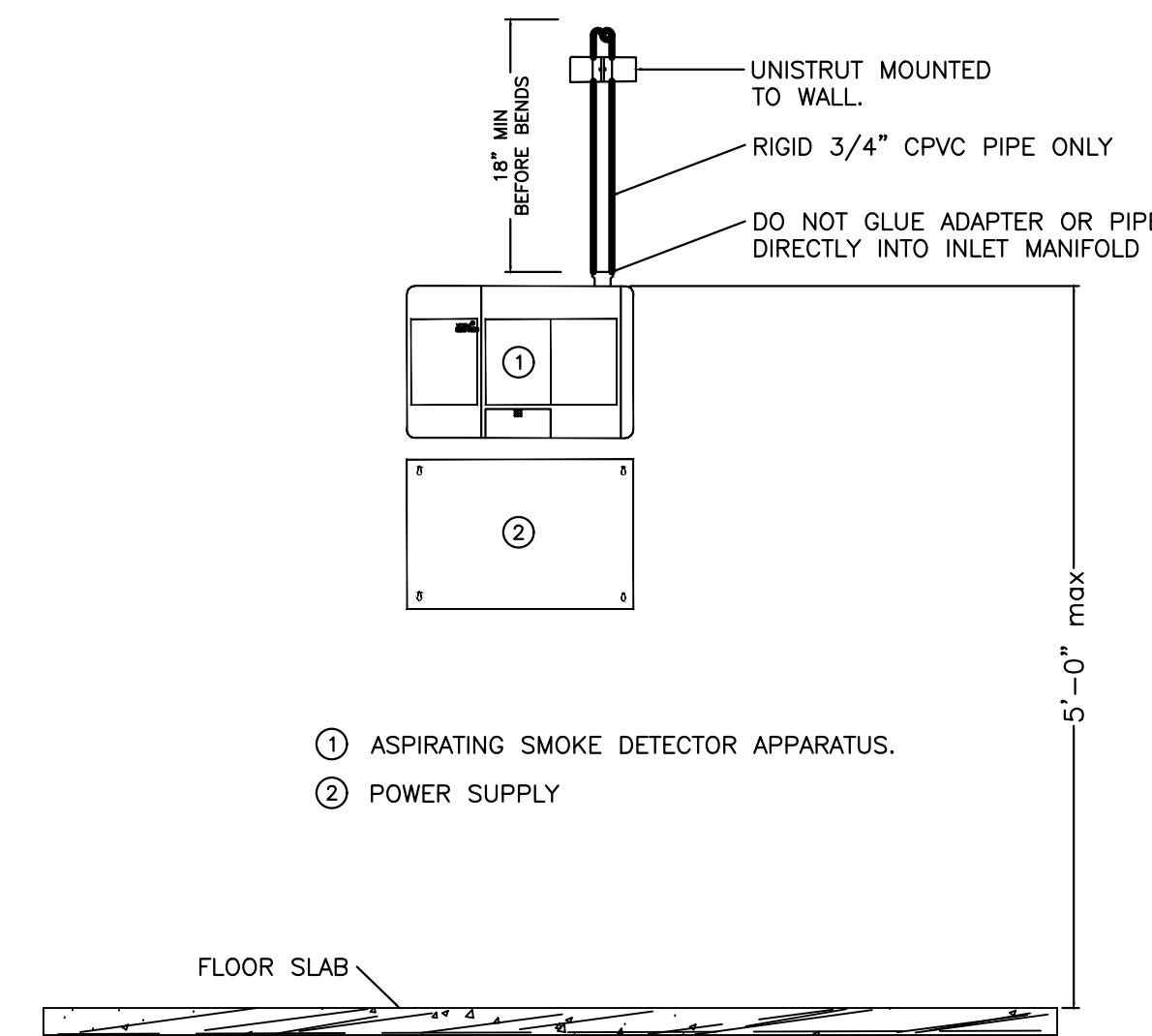

- NOTES:**
1. ASSD APPARATUS SHALL BE MOUNTED TO A WALL IN THE PROTECTED ROOM AT A MAXIMUM HEIGHT OF 5 FT TO TOP OF APPARATUS MEASURED ABOVE FINISHED FLOOR.
 2. MOUNTING LOCATION SHALL BE A FULLY ACCESSIBLE AND IN A VISIBLE LOCATION.
 3. MOUNTING OR ATTACHMENT TO SITE EQUIPMENT, CABLE TRAYS, MOVABLE WALLS, OTHER EQUIPMENT OR EQUIPMENT SUPPORTS IS NOT PERMITTED.
 4. PIPING NETWORK INSERTION INTO THE DETECTOR INLET SHALL NOT BE GLUED.
 5. FLEXIBLE TUBING FOR TERMINATION OF THE SAMPLING PIPE NETWORK INTO DETECTOR INLET IS NOT PERMITTED.
 6. AIR SAMPLING SMOKE DETECTOR ASSEMBLY SHALL BE INSTALLED IN ACCORDANCE WITH SPECIFICATIONS, THE MANUFACTURER'S INSTALLATION AND INSTRUCTION MANUALS.
 7. INSTALLATION TECHNIQUES SHALL BE IN COMPLIANCE WITH THE GEOGRAPHICAL SEISMIC ZONE REQUIREMENTS IN SEISMIC ZONES PER THE AHJ.

2 TYPICAL DETECTOR MOUNTING DETAIL

SCALE: NONE

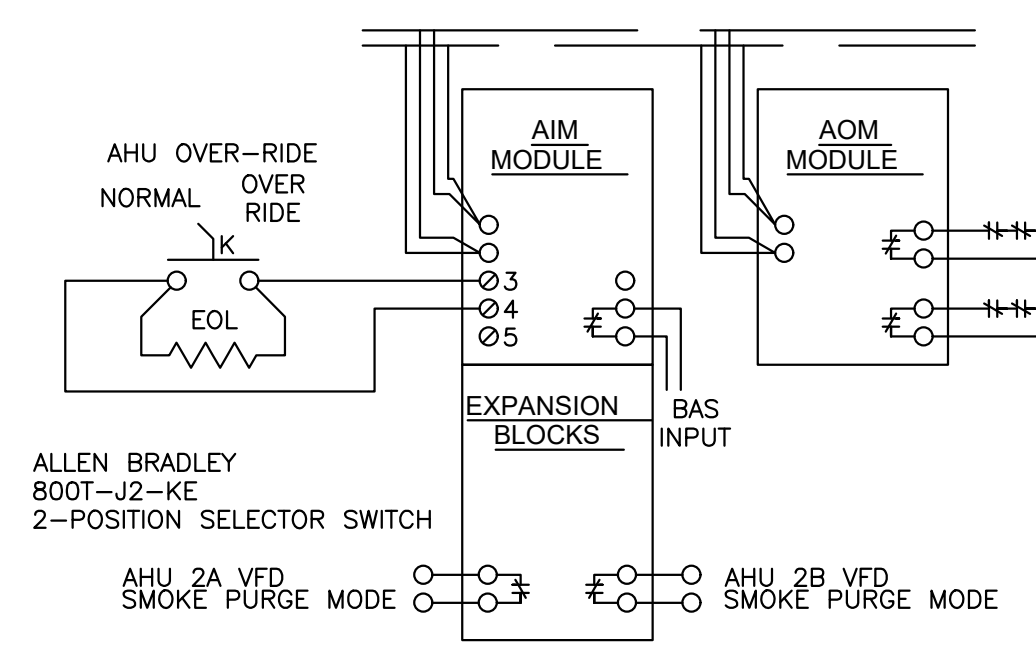

- NORMAL:**
- SYSTEM OPERATOR WITH FIRE ALARM INTERLOCK AND BAS UNDER NORMAL CONDITIONS.
- AHU OVER-RIDE:**
- ALARM MONITOR POSITION OF KEY SWITCH
 - RELEASE SHUTDOWN RELAYS AT CONTROL MODULES AT VFD TO ALLOW AHU TO RUN WHILE FACP IS IN ALARM CONDITION.
 - REPORT A TROUBLE SIGNAL TO EAMC.
 - SIGNALS BAS THAT AHU IS IN OVER-RIDE MODE.
- SMOKE PURGE:**
- VFD SMOKE PURGE MODE BYPASSED SAFETY CIRCUIT FOR VFD ENABLES START COMMAND
 - BAS INPUT PUTS AHU IN 100% OA AND OPENS CHW VALVE TO 100%.
- MOUNT SWITCH IN LOCKING ENCLOSURE SAFETY TECHNOLOGY INC MODEL 9100 OR EQUAL**

3 AIR HANDLER OVER-RIDE

SCALE: NONE

ASSDS/VESDA SYSTEM GENERAL NOTES

- BLAZEMASTER FIRE VESDA PIPE AND FITTINGS**
- PRODUCT DESCRIPTION:**
FIRE VESDA PIPE AND FITTINGS ARE EXTRUDED/MOLDED FROM PVC COMPOUNDS MANUFACTURED BY NOVE ON THE COMPOUNDS SHALL MEET CELL CLASS 23447 AS DEFINED BY ASTM D1784 AND SHALL BE CERTIFIED BY NSF INTERNATIONAL FOR USE WITH PORTABLE WATER.
- PIPE AND FITTINGS:**
1. PIPE SHALL MEET OR EXCEED THE REQUIREMENTS OF ASTM F442 IN STANDARD DIMENSION RATIO (SDR) 13.5.
 2. FITTINGS SHALL MEET OR EXCEED THE REQUIREMENTS OF ASTM F437 (SCHEDULE 80 THREADED), ASTM F438 (SCHEDULE 40 SOCKET) AND ASTM F439 (SCHEDULE 80 SOCKET).
 3. BOTH PIPE AND FITTINGS SHALL BE LISTED BY UL FOR USE IN WET AUTOMATIC FIRE VESDA SYSTEMS AND SHALL BEAR THE LOGO OF THE LISTING AGENCY. SEE UL FIRE PROTECTION EQUIPMENT DIRECTORY, CATEGORIES VMT AND HFHY.
 4. ALL PIPE DIMENSIONS SHALL BE FIELD VERIFIED.
- SOLVENT CEMENT:**
- A. ALL SOCKET TYPE JOINTS SHALL BE MADE UP EMPLOYING SOLVENT CEMENTS THAT MEET OR EXCEED THE REQUIREMENTS OF ASTM F493. THE STANDARD PRACTICE FOR SAFE HANDLING OF SOLVENT CEMENTS SHALL BE IN ACCORDANCE WITH ASTM F402. SOLVENT CEMENT SHALL BE LISTED BY NSF INTERNATIONAL FOR USE WITH PORTABLE WATER, AND APPROVED BY THE PVC MANUFACTURERS. THE SOLVENT CEMENTS SHALL BE COMPATIBLE WITH THEIR CPVC PIPE AND FITTINGS.
 - B. FOLLOW CPVC MANUFACTURER'S INSTRUCTIONS FOR SET AND CURE TIMES FOR SOLVENT CEMENT JOINTS. AVOID SIGNIFICANT STRESSES DURING SET AND CURE TIMES. DO NOT APPLY ANY STRESS THAT WILL DISTURB AN UNDRYED JOINT. VESDA FITTINGS SHALL BE ALLOWED TO CURE IN ACCORDANCE WITH THE MANUFACTURER'S GUIDELINES AND THE CONTRACTOR SHALL ASSURE THE OUTLETS ARE CLEAR OF ANY EXCESS CEMENT.
- INITIAL THRESHOLD SETTINGS FOR VESDA SYSTEMS**
- A. AT EACH VESDA DETECTOR THERE WILL BE 6 ADDRESSABLE POINTS:
 1. ALERT LEVEL: PROGRAM AT 30% BELOW ACTION THRESHOLD.
 2. ACTION LEVEL: PROGRAM AT 40% BELOW FIRE 1 THRESHOLD.
 3. FIRE 1: DIVIDE 1% (PER FEET) BY NUMBER OF HOLES IN OVERALL SYSTEM PIPE NETWORK.
 4. FIRE 2: PROGRAM AT 400% ABOVE FIRE 1 THRESHOLD.
 5. COMMON TROUBLE FROM DETECTOR
 6. POWER SUPPLY TROUBLE
- FINAL SETTINGS FOR VESDA SYSTEMS**
- A. AFTER 30 DAYS, THE THRESHOLD SETTINGS SHALL BE RE-SET AS FOLLOWS:
 1. ALERT LEVEL: TAKE THE RECORDED AVERAGE AMBIENT PEAK LEVEL AND DIVIDE THIS BY THE NUMBER OF SAMPLE PORTS IN THE SYSTEM PIPE NETWORK. MULTIPLY THIS NUMBER BY 150. THE RESULTING NUMBER SHALL BE PROGRAMMED INTO THE SYSTEM AS THE ALERT THRESHOLD.
 2. ACTION LEVEL: MULTIPLY THE NEW ALERT THRESHOLD BY 1.6. PROGRAM THIS NUMBER AS THE NEW ACTION THRESHOLD.
 3. FIRE 1: MULTIPLY THE NEW ACTION THRESHOLD BY 1.6. PROGRAM THIS NUMBER AS THE NEW FIRE 1 THRESHOLD.
 4. FIRE 2: MULTIPLY THE NEW FIRE 1 THRESHOLD BY 400%. PROGRAM THIS NUMBER AS THE NEW FIRE 2 THRESHOLD.

FIRE ALARM NOTE:
THE FLOOR PLAN SHOWN IS BASED UPON CONTRACT DRAWINGS DESIGNED BY OTHERS. THEREFORE, MONA ELECTRIC IS NOT RESPONSIBLE FOR ANY DESIGN DEFICIENCIES.

FIRE ALARM MATRIX														
DEVICE ACTIVATION	ANNUNCIATE ALARM AT FACP AND REMOTE ANNUNCIATOR	ANNUNCIATE TROUBLE AT FACP AND REMOTE ANNUNCIATOR	ANNUNCIATE SUPERVISORY	ENERGIZE ALL HORNS AND STROBES IN ENTIRE BUILDING	ACTIVATE EXTERIOR ALARM	SHUTDOWN AIR HANDLING EQUIPMENT PROTECTED BY DEVICE	SEND ALARM SIGNAL TO BMS SYSTEM	SEND TROUBLE SIGNAL TO BMS SYSTEM	SEND SUPERVISORY TO MONITORING CENTER	SEND PRE-ALARM TO MONITORING CENTER	SEND SIGNAL TO SECURITY SYSTEM	ACTIVATE PRE-ACTION SYSTEM RELEASING SOLENOID.		
DUCT SMOKE DETECTOR ACTIVATION		X			X				X					
VESDA ALERT			X							X				
VESDA ACTION			X							X				
VESDA ALARM 'FIRE 1' ACTIVATION	X			X		X	X			X				
VESDA ALARM 'FIRE 2' ACTIVATION	X			X	X	X	X			X				
VESDA DETECTOR TROUBLE		X					X	X						
VESDA POWER SUPPLY TROUBLE		X					X	X						

FIRE ALARM - SEQUENCE OF OPERATION

SCALE: NONE

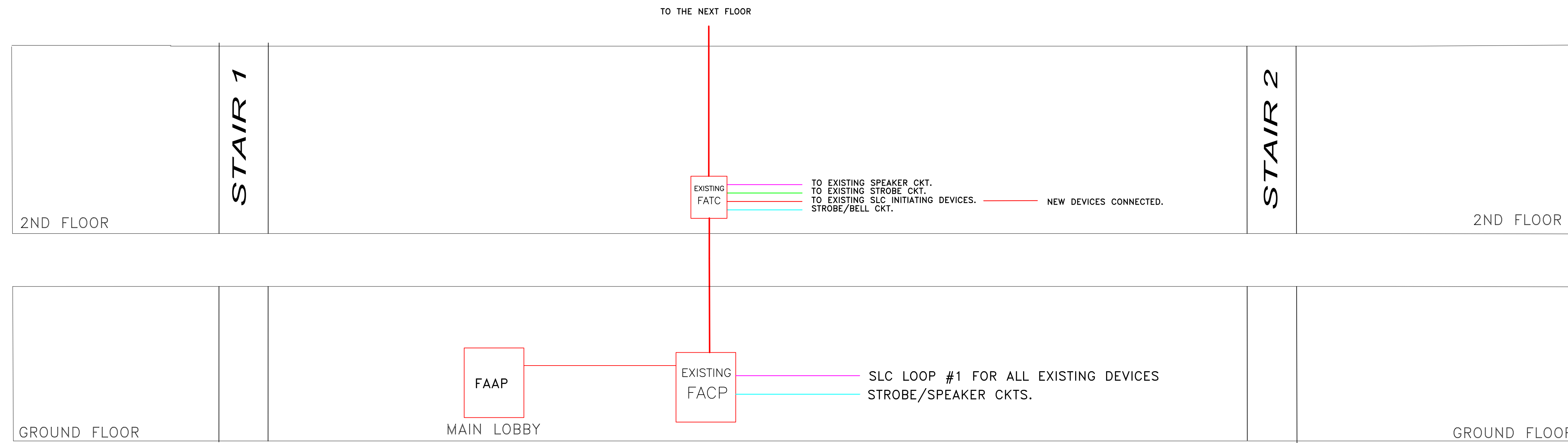

FIRE ALARM RISER DIAGRAM

SCALE: NONE

FIRE ALARM NOTE:
THE FLOOR PLAN SHOWN IS BASED UPON CONTRACT DRAWINGS DESIGNED BY OTHERS. THEREFORE, MONA ELECTRIC IS NOT RESPONSIBLE FOR ANY DESIGN DEFICIENCIES.

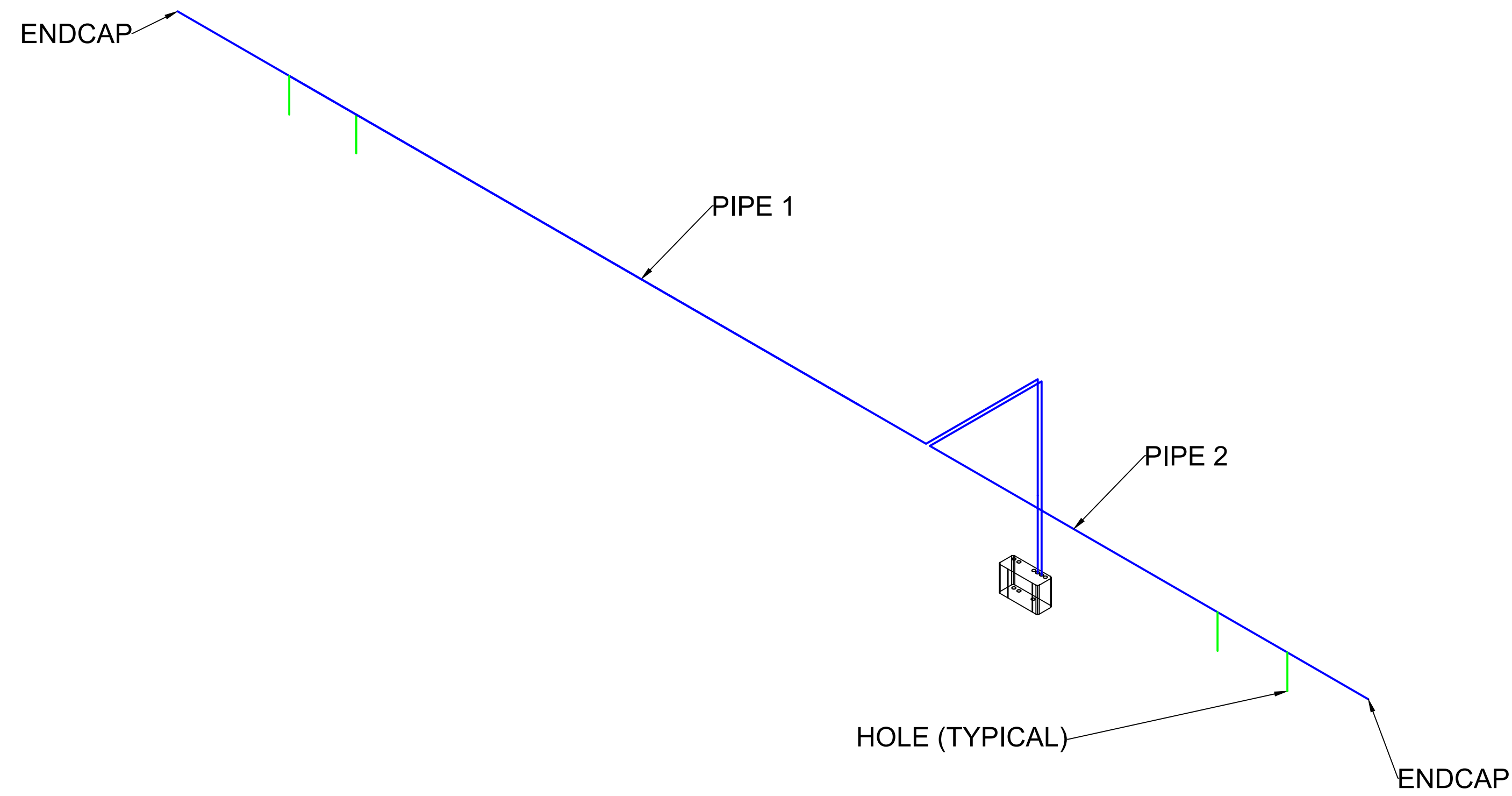

VESDA SYSTEM ISOMETRIC VIEW - DETECTOR 1

SCALE: 3/8"=1'-0"

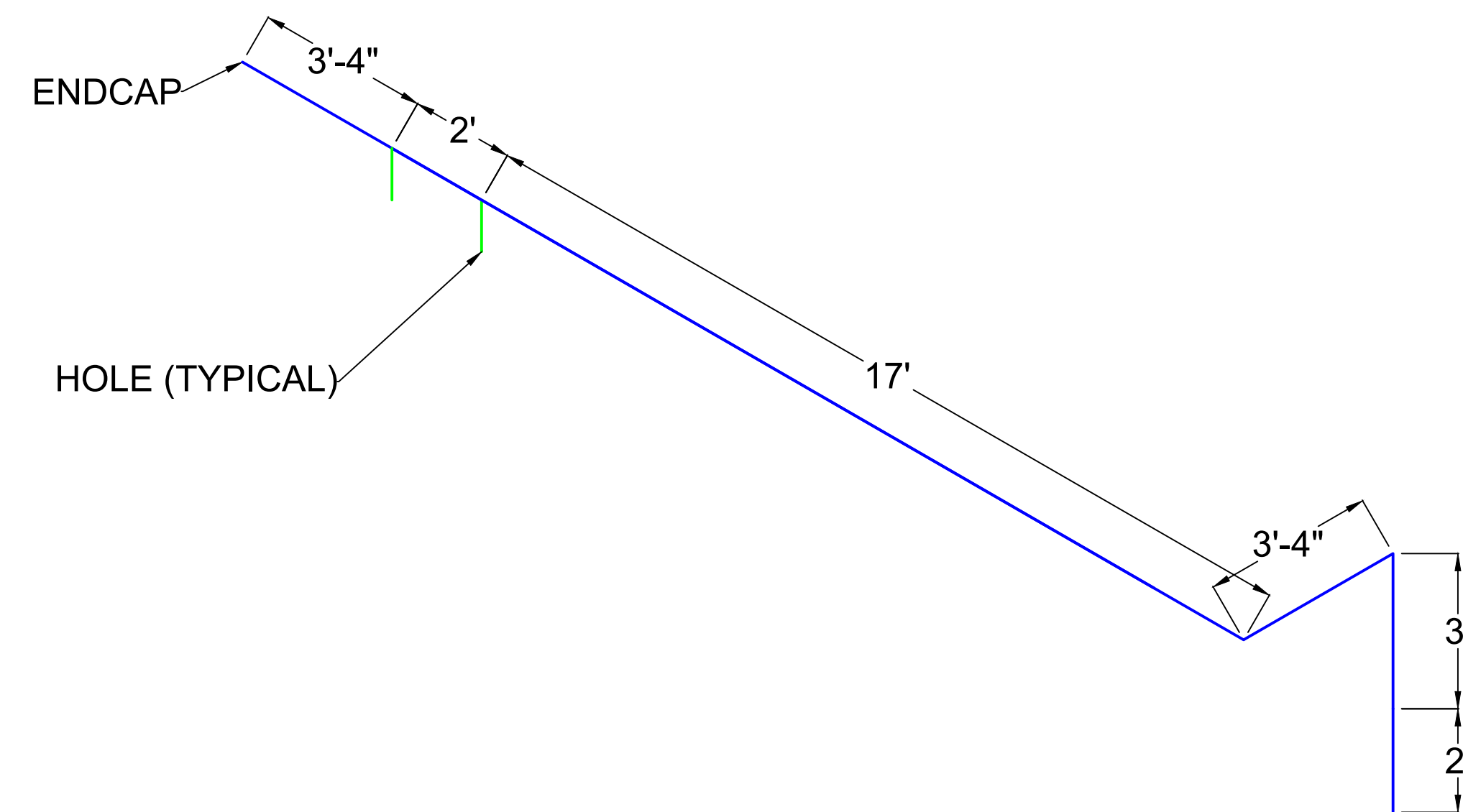

VESDA SYSTEM PIPE 1 MEASUREMENTS - DETECTOR 1

SCALE: 3/8"=1'-0"

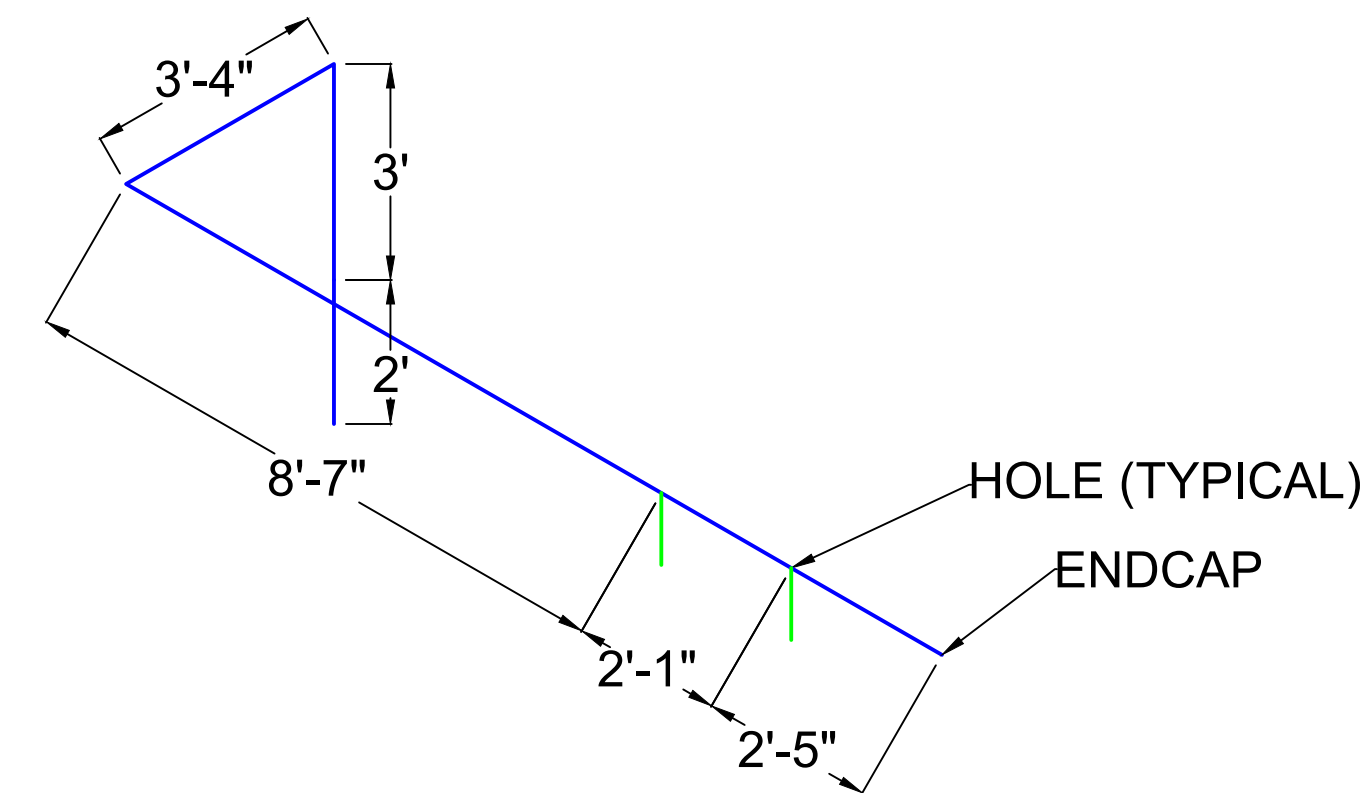

VESDA SYSTEM PIPE 2 MEASUREMENTS - DETECTOR 1

SCALE: 3/8"=1'-0"

FIRE ALARM NOTE:
 THE FLOOR PLAN SHOWN IS BASED UPON CONTRACT DRAWINGS
 DESIGNED BY OTHERS. THEREFORE, MONA ELECTRIC
 IS NOT RESPONSIBLE FOR ANY DESIGN DEFICIENCIES.

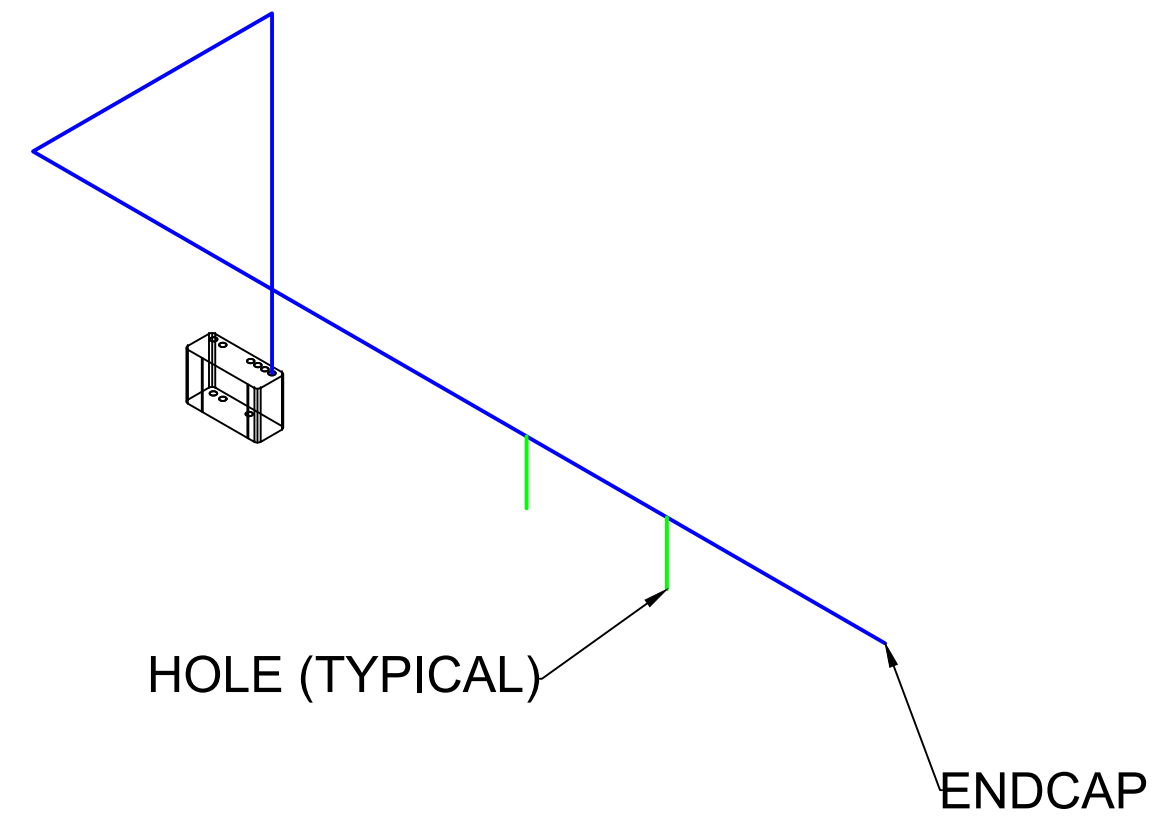

VESDA SYSTEM ISOMETRIC VIEW - DETECTOR 2

SCALE: 3/8"=1'-0"

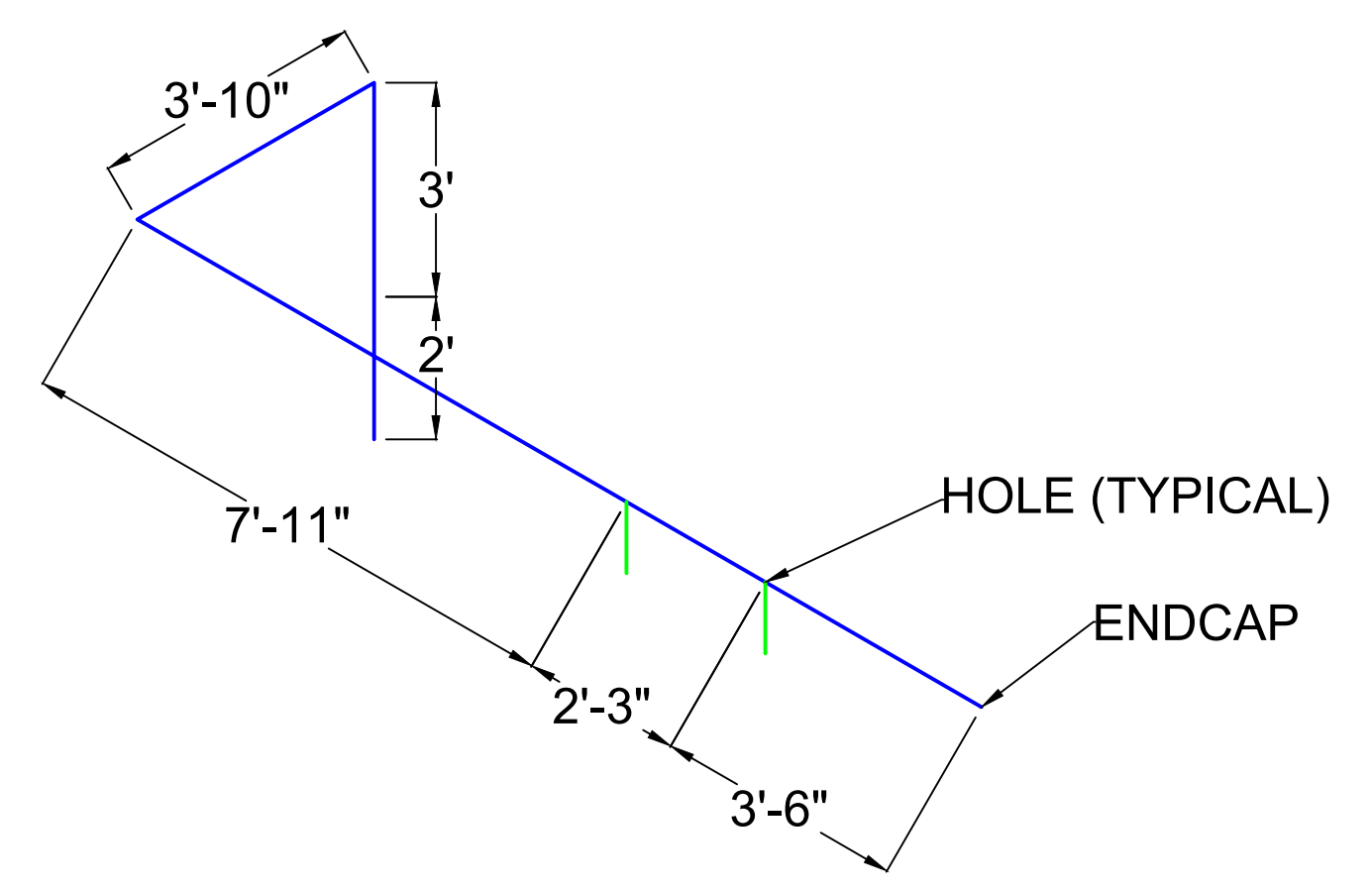

FIRE ALARM NOTE:
 THE FLOOR PLAN SHOWN IS BASED UPON CONTRACT DRAWINGS
 DESIGNED BY OTHERS. THEREFORE, MONA ELECTRIC
 IS NOT RESPONSIBLE FOR ANY DESIGN DEFICIENCIES.

VESDA SYSTEM PIPE 1 MEASUREMENTS - DETECTOR 2

SCALE: 3/8"=1'-0"



Bill Of Materials

Name

Site Address

Calculated By

Installer

Date 11/17/22

Detector : Detector 1

	Part Id	Description	Quantity	Packages
1	E700-SP-DCL-PNT	Sampling Point Label	6	1
2	VEU	VEU	1	1
3	VP-CLIP	Pipe Clip single point fix	11*	1
4	VP-COUP	Coupling	1	1
5	VP-EC	Endcap	2	1
6	VP-ELB-90	90 degrees Elbow	4	1
7	VP-P-210	VESDA pipe: 15 lengths of PVC Pipe with 0.874 ID / 1.05 OD	4	1
8	VP-UNION	Socket Union	2	1

Detector : Detector 2

	Part Id	Description	Quantity	Packages
9	E700-SP-DCL-PNT	Sampling Point Label	3	1
10	VEP-AXX-1P	VEP-1P	1	1
11	VP-CLIP	Pipe Clip single point fix	5*	1
12	VP-EC	Endcap	1	1
13	VP-ELB-90	90 degrees Elbow	2	1
14	VP-P-210	VESDA pipe: 15 lengths of PVC Pipe with 0.874 ID / 1.05 OD	2	1
15	VP-UNION	Socket Union	1	1

Project Totals

	Part Id	Description	Quantity	Packages
16	E700-SP-DCL-PNT	Sampling Point Label	9	1
17	VEP-AXX-1P	VEP-1P	1	1
18	VEU	VEU	1	1
19	VP-CLIP	Pipe Clip single point fix	16*	1
20	VP-COUP	Coupling	1	1
21	VP-EC	Endcap	3	1
22	VP-ELB-90	90 degrees Elbow	6	1
23	VP-P-210	VESDA pipe: 15 lengths of PVC Pipe with 0.874 ID / 1.05 OD	6	1
24	VP-UNION	Socket Union	3	1

Notes

*Based on clip spacing of 5'





Installation Data Pack

Pipe Type	America
Date	11/17/22
Units	US
Altitude	50'
Designed with Hole Sizes	1/8"

Detector : Detector 1

Type	VEU
Sensitivity Objective	NFPA_SFD
Endcap Usage	Create a Balanced Design
Application Defaults	default
Aspirator Speed	4
Air Temperature	68.0°F
Absolute Pressure	1011hPa
System Flowrate	44.1l/min
Total Pipe Length	52' 1"
Number Of Sample Points	6
Maximum Transport Time	13sec
Maximum Allowed TT	90sec
Minimum Hole Flow Rate	2.0l/min
Exhaust Length	0'
Exhaust Diameter	0.874
Exhaust Pressure Drop	0Pa
Invert	No

Thresholds

Safety Factor (% reduction in alarm threshold) 0%

	Alert	Action	Fire 1	Fire 2
Recommended Thresholds (%/ft)	0.1050	0.1500	0.2500	0.9852
Smoke at least sensitive hole (%/ft)	0.6663	0.9519	1.5865	6.2500

Group Details

	Hole Sensitivity	Flow	Pressure	Transport Time	Hole Diameter	[Default Group]
Aggregate smoke from holes						0
Group Type						
Max Target Aggregate Sensitivity						
Min Target Aggregate Sensitivity						
Contribution ratio(%)						
Applied Max Aggregate Sensitivity						
Applied Min Aggregate Sensitivity						
Target Suction Pressure						25
Target Balance						70
Exclude from Autobalance						
1:Section0-1	1.5846	7.0	262	10	1/8"	✓
1:Section0-2	1.5860	6.9	262	11	1/8"	✓
1:Section0-3	1.3653	8.1	261	13	1/8"	✓
2:Section0-1	1.5750	7.0	265	8	1/8"	✓
2:Section0-2	1.5764	7.0	265	9	1/8"	✓
2:Section0-3	1.3568	8.1	265	11	1/8"	✓
Number of holes						6
Flow Share(%)						100
Aggregate Sensitivity						
Balance(%)						86
Suction pressure (least)						261

Pipe:1

Total Pipe Length 30' 8"
 Ambient Pressure 0Pa
 Sector Pressure 273Pa
 Number of Sample Points 3
 Pipe Flowrate 22.0l/min

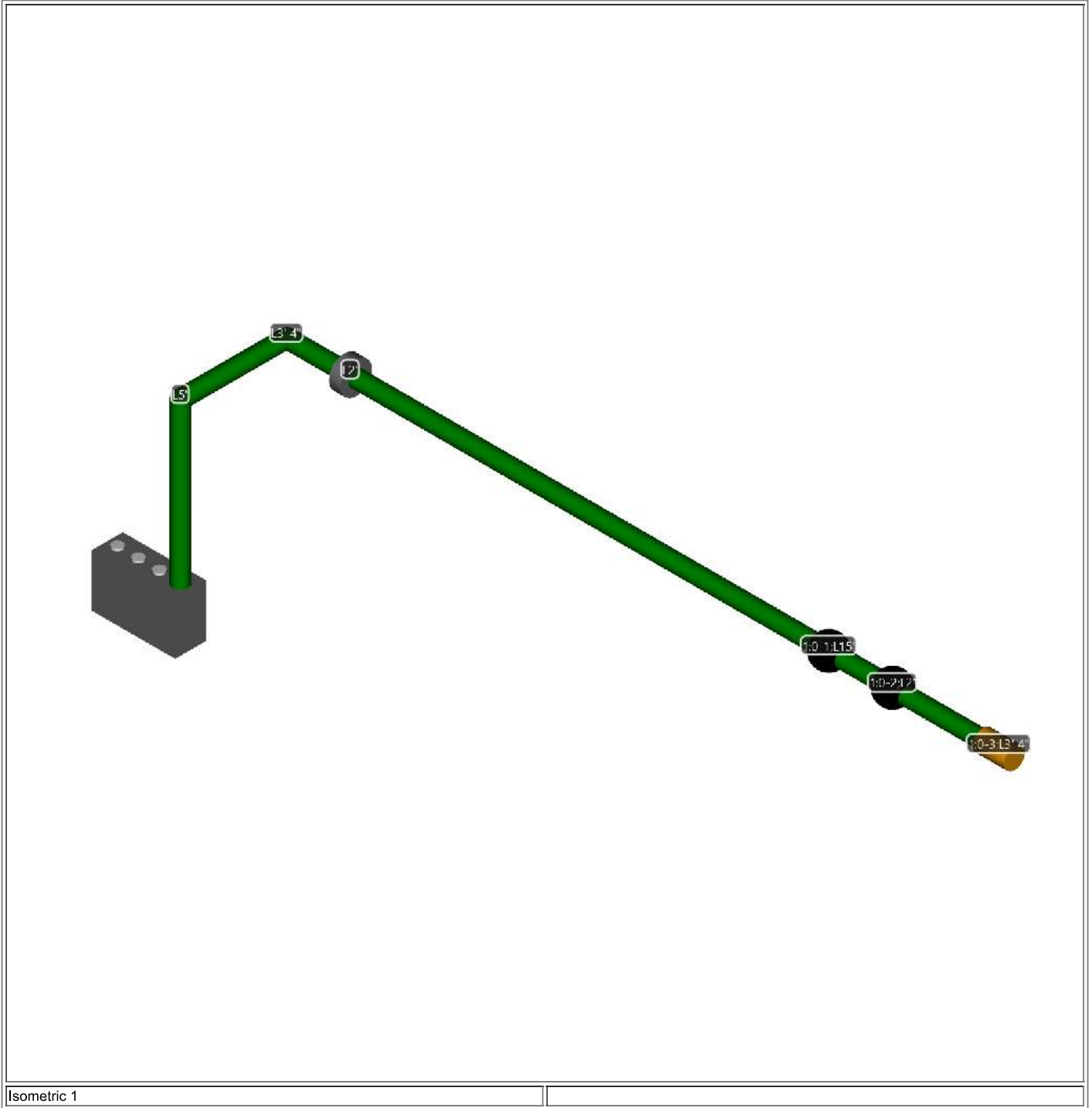

Isometric 1

Section0

Pipe Diameter 0.874

#		Distance ft	Relative ft	Direction	Hole Diameter in	Capillary Length	Transport Time sec	Pressure Pa	Flow l/min	Flow %	Hole Sensitivity %/ft	Pipe Diameter in	Capillary Diameter	Intersection Pressure
-	Bend 90	5'	5'	F										
-	Bend 90	8' 4"	3' 4"	R										
-	Socket Union	10' 4"	2'									0.874		
1:Section0-	Hole	25' 4"	15'		1/8"		10	262	7.0	15.8	1.5846	0.874		

1														
1:Section0-2	Hole	27' 4"	2'		1/8"		11	262	6.9	15.8	1.5860	0.874		
1:Section0-3	Endcap	30' 8"	3' 4"		1/8"		13	261	8.1	18.3	1.3653	0.874		

Pipe:2

Total Pipe Length 21' 5"
 Ambient Pressure 0Pa
 Sector Pressure 273Pa
 Number of Sample Points 3
 Pipe Flowrate 22.1l/min

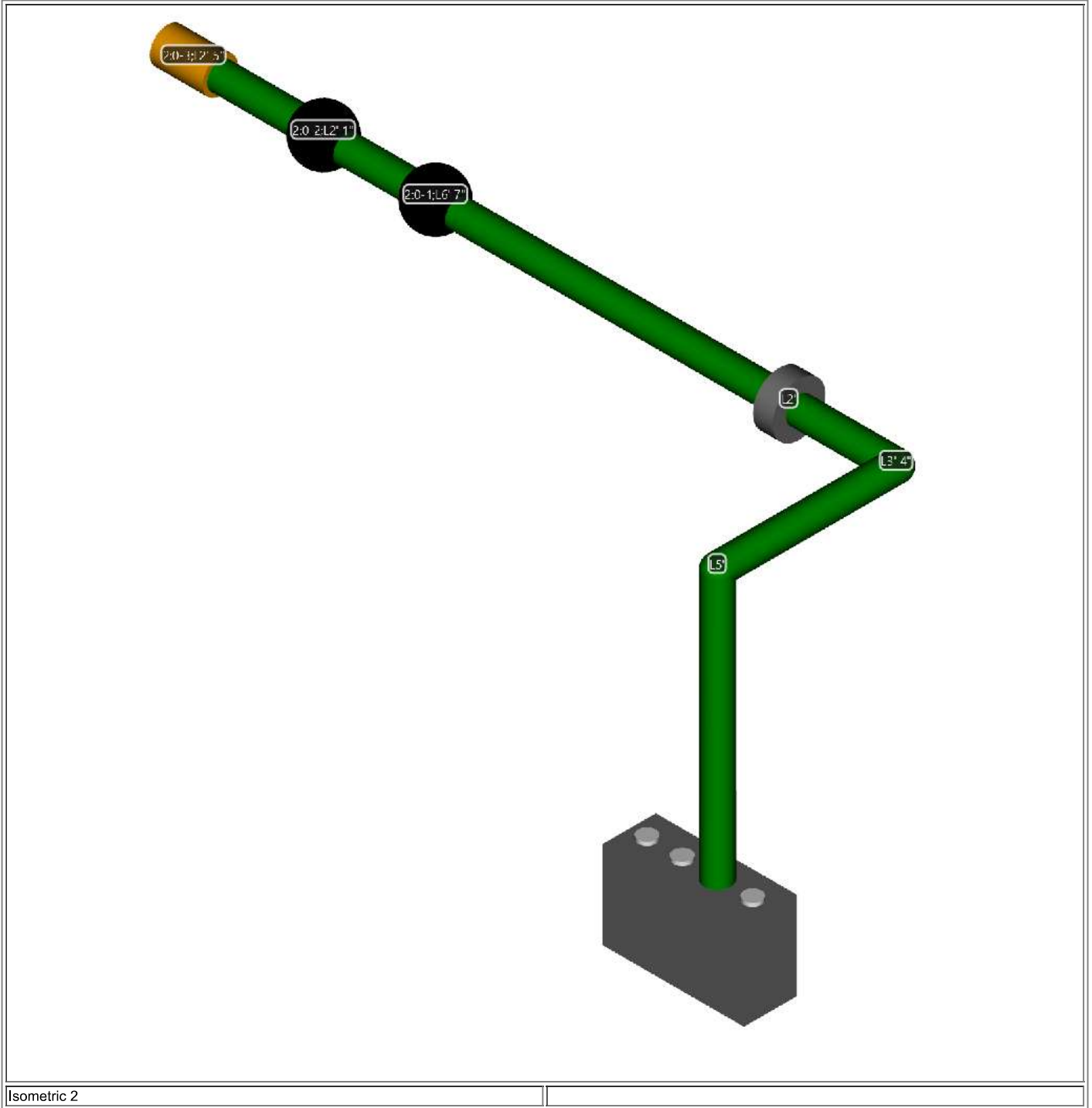

Isometric 2

Section0

Pipe Diameter 0.874

#		Distance ft	Relative ft	Direction	Hole Diameter in	Capillary Length	Transport Time sec	Pressure Pa	Flow l/min	Flow %	Hole Sensitivity %/ft	Pipe Diameter in	Capillary Diameter	Intersection Pressure
-	Bend 90	5'	5'	F										
-	Bend 90	8' 4"	3' 4"	L										
-	Socket Union	10' 4"	2'									0.874		
2:Section0-	Hole	16' 11"	6' 7"		1/8"		8	265	7.0	15.9	1.5750	0.874		

1														
2:Section0-2	Hole	19'	2' 1"		1/8"		9	265	7.0	15.9	1.5764	0.874		
2:Section0-3	Endcap	21' 5"	2' 5"		1/8"		11	265	8.1	18.4	1.3568	0.874		

Detector : Detector 2

Type	VEP-1P
Sensitivity Objective	NFPA_SFD
Endcap Usage	Create a Balanced Design
Application Defaults	default
Air Temperature	68.0°F
Absolute Pressure	1011hPa
System Flowrate	22.1l/min
Total Pipe Length	22' 6"
Number Of Sample Points	3
Maximum Transport Time	12sec
Maximum Allowed TT	60sec
Minimum Hole Flow Rate	2.0l/min
Exhaust Length	0'
Exhaust Diameter	0.874
Exhaust Pressure Drop	0Pa
Invert	No

Thresholds

Safety Factor (% reduction in alarm threshold) 10%

	Alert	Action	Fire 1	Fire 2
Recommended Thresholds (%/ft)	0.2100	0.3000	0.5000	1.7783
Smoke at least sensitive hole (%/ft)	0.7382	1.0545	1.7575	6.2500

Group Details

	Hole Sensitivity	Flow	Pressure	Transport Time	Hole Diameter	[Default Group]
Aggregate smoke from holes						0
Group Type						
Max Target Aggregate Sensitivity						
Min Target Aggregate Sensitivity						
Contribution ratio(%)						
Applied Max Aggregate Sensitivity						
Applied Min Aggregate Sensitivity						
Target Suction Pressure						25
Target Balance						70
Exclude from Autobalance						
1:Section0-1	1.5800	7.0	265	8	1/8"	✓
1:Section0-2	1.5816	7.0	265	9	1/8"	✓
1:Section0-3	1.3615	8.1	265	12	1/8"	✓
Number of holes						3
Flow Share(%)						100
Aggregate Sensitivity						
Balance(%)						86
Suction pressure (least)						265

Pipe:1

Total Pipe Length 22' 6"
 Ambient Pressure 0Pa
 Sector Pressure 273Pa
 Number of Sample Points 3
 Pipe Flowrate 22.1l/min

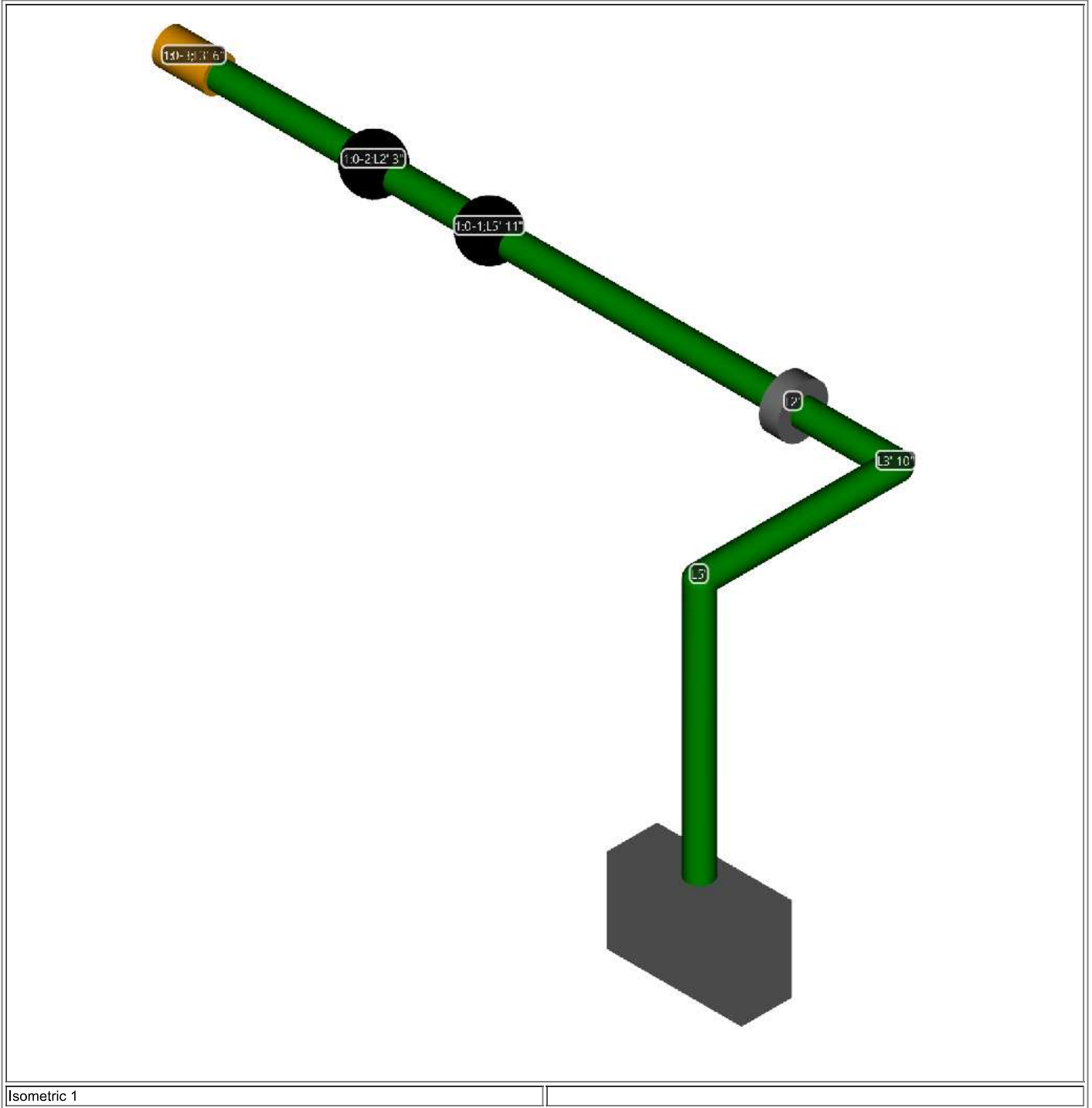

Section0

Pipe Diameter 0.874

#		Distance ft	Relative ft	Direction	Hole Diameter in	Capillary Length	Transport Time sec	Pressure Pa	Flow l/min	Flow %	Hole Sensitivity %/ft	Pipe Diameter in	Capillary Diameter	Intersection Pressure
-	Bend 90	5'	5'	F										
-	Bend 90	8' 10"	3' 10"	L										
-	Socket Union	10' 10"	2'									0.874		
1:Section0-	Hole	16' 9"	5' 11"		1/8"		8	265	7.0	31.6	1.5800	0.874		

1														
1:Section0-2	Hole	19'	2' 3"		1/8"		9	265	7.0	31.6	1.5816	0.874		
1:Section0-3	Endcap	22' 6"	3' 6"		1/8"		12	265	8.1	36.7	1.3615	0.874		

